

# Safety Standards

of the  
Nuclear Safety Standards Commission (KTA)

---

**KTA 1507 (2022-11)**

**Monitoring the Discharge of Radioactive Substances  
from Research Reactors**

(Überwachung der Ableitungen radioaktiver Stoffe bei  
Forschungsreaktoren)

The previous versions of this safety  
standard were issued in 1998-06, 2012-11 and 2017-11

---

If there is any doubt regarding the information contained in this translation, the German wording shall apply.

Editor:

KTA-Geschäftsstelle

c/o Bundesamt fuer die Sicherheit der nuklearen Entsorgung (BASE)

Willy-Brandt-Str. 5 • 38226 Salzgitter • Germany

Telephone: +49 (0) 30 184321-2907



# KTA SAFETY STANDARD

November  
2022

## Monitoring the Discharge of Radioactive Substances from Research Reactors

KTA 1507

Previous versions of this safety standard: 1998-06 (BAnz No. 172a of September 15, 1998)  
1984-03 (BAnz No. 125a of July 7, 1984)  
2012-11 (BAnz AT 23.01.2013 B5)  
2017-11 (BAnz AT 05.02.2018 B3)

### Contents

Basic Principles .....	5
1 Scope .....	5
2 Definitions .....	5
3 Monitoring the Radioactive Substances Discharged with Vent Air during Specified Normal Operation.....	7
3.1 General Requirements.....	7
3.2 Radioactive Noble Gasses .....	7
3.3 Radionuclides Bound to Aerosol Particles .....	8
3.4 Radioactive Gaseous Iodine.....	8
3.5 Tritium.....	9
3.6 Radioactive Strontium.....	10
3.7 Alpha Emitters .....	10
3.8 Carbon-14.....	10
3.9 Sampling.....	10
3.10 Non-central Monitoring of Emissions .....	11
4 Monitoring the Radioactive Substances Discharged with Vent Air during Design Basis Accidents .....	13
4.1 General Requirements.....	13
4.2 Radioactive Noble Gasses .....	13
4.3 Radionuclides Bound to Aerosol Particles .....	13
4.4 Radioactive Gaseous Iodine.....	14
4.5 Tritium.....	14
4.6 Sampling.....	14
5 Monitoring of Radioactive Substances Discharged with Water.....	15
5.1 Radioactively Contaminated Waste Water .....	15
5.2 Cooling Water (Intermediate Cooling Circuits).....	16
6 Design and Construction of Monitoring Equipment.....	20
6.1 General Requirements for Stationary Monitoring Equipment.....	20
6.2 Special Requirements for Stationary Measurement Equipment for Monitoring the Discharge of Radioactive Substances during Design Basis Accidents.....	21
7 Maintenance of Stationary Monitoring Equipment .....	22
7.1 Servicing and Repair .....	22
7.2 Tests.....	22
7.3 Removal of Defects .....	23
7.4 Test certificates .....	23
8 Measurement Results.....	25
8.1 Documentation .....	25
8.2 Report to the Proper Authorities .....	25
Appendix A Instruction for Preparing Monthly, Quarterly and Annual Mixture Samples for the Detailed Assessment Measurements.....	28
Appendix B Regulations Referred to in this Safety Standard.....	29

PLEASE NOTE: Only the original German version of this safety standard represents the joint resolution of the 35-member Nuclear Safety Standards Commission (Kerntechnischer Ausschuss, KTA). The German version was made public in the Federal Gazette (Bundesanzeiger) on July 25, 2023. Copies of the German versions of the KTA safety standards may be mail-ordered through the Wolters Kluwer Deutschland GmbH (info@wolterskluwer.de). Downloads of the English translations are available at the KTA website (<http://www.kta-gs.de>).

All questions regarding this English translation should please be directed to the KTA office:

KTA-Geschäftsstelle c/o BASE, Willy-Brandt-Strasse 5, D-38226 Salzgitter, Germany or [kta-gs@base.bund.de](mailto:kta-gs@base.bund.de)

**Comments by the Editor:**

Taking into account the meaning and usage of auxiliary verbs in the German language, in this translation the following agreements are effective:

- shall** indicates a mandatory requirement,
- shall basically** is used in the case of mandatory requirements to which specific exceptions (and only those!) are permitted. It is a requirement of the KTA that these exceptions - other than those in the case of **shall normally** - are specified in the text of the safety standard,
- shall normally** indicates a requirement to which exceptions are allowed. However, exceptions used shall be substantiated during the licensing procedure,
- should** indicates a recommendation or an example of good practice,
- may** indicates an acceptable or permissible method within the scope of this safety standard.

## Basic Principles

(1) The safety standards of the Nuclear Safety Standards Commission (KTA) have the task of specifying those safety-related requirements which shall be met with regard to precautions to be taken in accordance with the state of science and technology against damage arising from the construction and operation of the plant (Sec. 7 para. 2 subpara. 3 Atomic Energy Act - AtG) in order to attain the protective goals specified in AtG, the Radiation Protection Act (StrlSchG) and the Radiation Protection Ordinance (StrlSchV).

(2) The stationary and mobile radiation protection instrumentation has, among others, the dual purpose of protecting persons inside and outside of the plant from ionizing radiation and of verifying the specified normal functioning of the equipment for

- a) retaining solid, liquid and gaseous radioactive substances inside the designated enclosures,
- b) handling and the controlled conduction of radioactive substances within the plant, and
- c) monitoring the discharge of radioactive substances.

Safety standard series KTA 1500 specifies detailed safety related requirements regarding this radiation protection instrumentation.

(3) The present safety standard KTA 1507 contains the requirements that apply to the technical equipment and the supplementary administrative measures that are considered necessary for monitoring the discharge of radioactive substances with air and water in research reactors during specified normal operation and in the case of design basis accidents.

(4) Monitoring the discharge of radioactive substances contributes to meeting the requirements of Sec. 8 StrlSchG, and Secs 99, 102 and 103 StrlSchV, which specifically specify that it must be ensured

- a) that any exposure or contamination of man and environment is minimized and, even if below the respective limits specified in StrlSchG, is kept as low as possible taking into account the state of the art and all circumstances of the individual case (Sec. 8 para. 2 StrlSchG),
- b) that no unmonitored discharge of radioactive substances into the environment will occur (Sec. 99 para. 4 StrlSchV, and
- c) that discharges are monitored and reported to the proper authority at least once a year, specifying their kind and activity (Sec. 103 para. 1 StrlSchV). The corresponding monitoring equipment must meet the requirements of Sec. 90 StrlSchV.

(5) The tasks of monitoring the discharge of radioactive substances comprises

- a) the detailed assessment of the discharged radioactive substances, thus providing a basis for evaluating the radiological effects, and
- b) the automatic initiation of alarm signals.

(6) In addition to meeting the requirements of this safety standard, the federal Water Resources Act (WHG) and the water act of the respective federal State (*Bundesland*) shall also be fulfilled.

(7) When discharging waste water into a public sewage system, the individual requirements and restrictions specified in communal statutory law shall be taken into consideration.

## 1 Scope

(1) This safety standard shall apply to the equipment and facilities used for monitoring the discharge of gaseous sub-

stances, substances bound to aerosol particles and liquid radioactive substances from stationary research reactors with a power larger than 50 kW during specified normal operation and in the case of design basis accidents including the discharge from all plant components included in the nuclear license.

Note:

Examples for such plant components are neutron conductors, cold and hot neutron sources and irradiation facilities.

(2) In the case of mobile research reactors or research reactors with a power less than or equal to 50 kW and of zero power reactors, e.g. training reactors and critical assemblies, the present safety standard should be applied only to the extent that is reasonable taking all circumstances of the individual case into account.

(3) Whenever liquid radioactive substances are delivered to authorized third parties, e.g., central decontamination facilities or State collection facilities, the monitoring of these substances is not subject to the requirements of the present safety standard.

Note:

Secs. 85 and 94 StrlSchV pertain specifically to the transfer of radioactive substances.

## 2 Definitions

(1) Bleed water

Bleed water is that portion of the circulating coolant that is discharged from the secondary and tertiary cooling circuits in order to keep the amount of substances contained in the coolant within permissible limits.

(2) Discharge of radioactive substances

The discharge of radioactive substances is the intentional release of liquid radioactive substances, radioactive substances bound to aerosol particles or gaseous radioactive substances from the plant along designated paths.

(3) Discrimination of measurement equipment

The discrimination of measurement equipment is the ratio of the displayed value of the measurement parameter and the actual value of this measurement parameter.

(4) Specified normal operation

Specified normal operation comprises

- a) operating processes for which the plant, assuming the able function of all systems (fault free condition), is intended and suited (normal operation);
- b) operating processes which occur as a cause of a malfunctioning of plant components or systems (fault condition), insofar as safety related reasons do not stand in the way of continuing operation (abnormal operation);
- c) maintenance procedures (inspection, servicing, repair).

(5) Detailed assessment of radioactive substances

The detailed assessment is a special form of monitoring consisting of identifying, and determining the activity of, the radionuclides or radionuclide groups discharged over a given time span. For detailed assessment measured value is used. The measurement uncertainty is indicated separately.

(6) Cesium-137 equivalent (water)

Cesium-137 equivalent is a calculated measurement parameter in units of Becquerel per cubic meter (Bq/m<sup>3</sup>). It is determined

by multiplying the measured gamma count rate of a measurement source with a ratio of activity concentration and gamma count rate determined under the same geometric conditions for a standard solution of Cesium-137.

**Note:**

The measurements, both of the measurement source and of the Cesium-137 standard solution, are performed with a similar measuring equipment, the same measurement arrangement and similar radiation sources and the same gamma ray energy ranges.

(7) Double determination

Double determination is the activity measurement on aliquot portions of a representative sample after having performed identical preparatory procedural steps on these portions (e.g., concentration by evaporation, radio-chemical separation).

(8) Decision threshold

The decision threshold is a calculated value of a parameter (e.g., activity, activity concentration, specific activity) for the comparison with a measurement value in order to decide whether the parameter has contributed to the measurement or has had a zero effect.

**Note:**

- (1) Decision thresholds are determined in accordance with DIN EN ISO 11929-1.
- (2) Application examples are given in report KTA-GS 82.

(9) Research reactor

A research reactor is a nuclear reactor which is operated exclusively for at least one of the following purposes:

- a) utilization of the radiation produced by nuclear fission,
- b) measurement of nuclear physics data, or
- c) measurement of reactor physics data.

(10) Total alpha activity

The total alpha activity is the radioactivity determined by an integral measurement of the alpha particles emitted by a radioactive substance which is, then, related to the reference nuclide used for calibrating the measurement equipment.

(11) Total beta activity

The total beta activity is the radioactivity determined by an integral measurement of the beta particles emitted by a radioactive substance which is, then, related to the reference nuclide used for calibrating the measurement equipment.

(12) Overall dissipation factor (sampling airborne substances)

The overall dissipation factor is a correction factor to be applied to the determined discharge of airborne radioactive substances. It is, essentially, comprised of factors from changes of the activity concentrations of airborne radioactive substances arising from

- a) a determination in a partial air stream with a sampling rake,
- b) a non-isokinetic sampling,
- c) transport through the sampling pipe (pipe factor), and
- d) the transport in the accumulating and measurement equipment.

(13) Calibration of the measurement equipment for radiation monitoring

The calibration of the measurement equipment for radiation monitoring is the determination of the relationship between the value defined by specific norms (e.g., activity of the calibration

source) and the displayed value (e.g., count rate) of the measurement parameter.

(14) Measurement medium

The measurement medium is a sample taken from the medium to be monitored that – possibly after an engineering procedural treatment such as heating, filtration, dilution – flows through the measurement volume (i.e., that region for which the discrimination of the respective measurement equipment was determined during calibration).

(15) Mixture sample

A mixture sample is a mixture of individual samples or cumulative samples, or of parts of these samples, taken within a specified time period.

(16) Detection limit

The detection limit is a calculated value of a measurement parameter (e.g., activity, activity concentration, specific activity) that shall normally be compared to a predetermined reference value in order to decide whether or not the measuring procedure is suitable for a particular measurement task.

**Note:**

- (1) Decision thresholds are determined in accordance with DIN EN ISO 11929-1.
- (2) Application examples are given in report KTA-GS 82.

(17) Representative sample (of discharges)

A representative sample is a particular sample the examination of which allows determining the discharged radioactive substances according to their kind and activity.

(18) Pipe factor

The pipe factor is the ratio – determined in a stationary condition – of the activity concentration of a radionuclide or radionuclide group at the entry port of a sampling probe and the activity concentration at the connection point of the accumulating or measurement equipment for monitoring the activity concentration of gaseous radionuclides or radionuclides bound to aerosol particles.

(19) Cumulative sample

A cumulative sample is a sample accumulated by continuous or quasi-continuous sampling within a specified time period.

(20) Threshold value

A threshold value is a plant-internal value the exceedance of which would require taking certain measures.

(21) Design basis accident

A design basis accident is a chain of events which, upon its occurrence, would require interruption of plant operation or of a task activity for reasons of safety, and which shall be considered in the plant design or for which, with regard to the task activity, protective measures shall be provided.

(22) Monitoring

Monitoring is a collective term for all different types of a controlled determination of physical parameters and includes comparing the results with specified values.

**Notes:**

- (1) Monitoring is performed
  - a) by continuous measurements or
  - b) by analyses of samples (e.g. in a laboratory) or

c) by a combination of measurement values and always in connection with the comparison of the results with specified values of the physical parameters (e.g., licensed limit values, operational values).

(2) To verify compliance with licensed limit values the upper limit of the probabilistically symmetric coverage interval is applied.

### (23) Coverage interval

The coverage interval contains the area of potential true values of the measurand based on available information with a specified probability.

**Note:**

The limits of the probabilistically symmetric coverage interval are determined in accordance with DIN EN ISO 11929-1.

## 3 Monitoring the Radioactive Substances Discharged with Vent Air during Specified Normal Operation

### 3.1 General Requirements

(1) The radioactive substances discharged during specified normal operation shall be determined according to kind and activity in accordance with the requirements specified in this Section 3. With regard to the accumulation and measurement procedures, the following nuclides and nuclide groups shall be differentiated between:

- a) radioactive noble gasses,
- b) radionuclides bound to aerosol particles,
- c) radioactive gaseous iodine,
- d) tritium,
- e) radioactive strontium,
- f) alpha emitters, and
- g) carbon-14.

(2) With regard to monitoring the discharge of radioactive substances, the continuous or non-continuous sampling, the measuring and the accumulating of samples shall normally be performed in a partial air stream of the vent air. The volumetric flow of all partial air streams shall be continuously monitored.

(3) The volumetric flow of the vent air shall be measured and recorded continuously; the measurement uncertainty of the volumetric flow measurement shall be specified.

(4) With regard to the continuous measurement of radionuclides bound to aerosol particles and radioactive gaseous iodine, a deviation by more than 20 % of the volumetric flow of the partial air stream from its nominal value shall set off an alarm in the control room.

(5) Regarding the detailed assessment of radionuclides bound to aerosol particles, radioactive gaseous iodine, tritium, radioactive strontium, carbon-14 and other alpha emitters, the volumetric flow shall be measured and a deviation by more than 20 % of the volumetric flow of the partial air stream from its nominal value shall set off an alarm in the control room. This requirement may be dispensed with if piston pumps are used.

### 3.2 Radioactive Noble Gasses

#### 3.2.1 Continuous measurement

(1) The radioactive noble gasses discharged with vent air shall be continuously determined by beta-measurements and shall be continuously monitored with respect to a threshold value. This requires at least one continuous measurement and recording of the total beta activity concentration in connection with the continuous measurement and recording of the volumetric flow of vent air.

(2) In order to prevent any falsification of measurement values, a high-efficiency particulate air filter of at least Filter Class E12 in accordance with DIN EN 1822-1 shall be installed upstream of the measurement equipment.

(3) The detection limit of the measurement equipment for determining the activity concentration shall not exceed  $1 \times 10^4$  Bq/m<sup>3</sup> with respect to xenon-133 for a measurement duration of ten minutes.

(4) Taking the volumetric flow of vent air into account, the upper end of the measurement range shall be such that, relative to the vent air volume discharged in a 24 h period, it is possible to determine discharge rates at least up to one tenth of the licensed annual limit value.

(5) If the design of the activity measurement equipment does not provide for redundancy, the activity discharge from radioactive noble gasses shall be estimated for the duration of any outage duration of this measurement equipment; given a known volumetric flow of vent air, the estimation shall be based on some other permanently installed instrumentation. The outage duration may not exceed a time period of 3 days.

#### 3.2.2 Detailed assessment

(1) The radioactive noble gasses discharged with vent air shall be subjected to a detailed assessment. This requires that a beta measurement is performed to determine the discharge rate of the total beta activity specified under Section 3.2.1 para. 1 taking the proportion of each individual nuclide in the nuclide composition into account.

(2) The non-continuous determination of the nuclide composition shall be performed on single representative samples taken in quarterly intervals. These samples shall be analyzed without delay. In this context, the radionuclides listed in **Table 3-1** shall be taken into account.

<i>Radionuclides</i>	
Argon-41	Xenon-131m
Krypton-85	Xenon-133
Krypton-85m	Xenon-133m
Krypton-87	Xenon-135
Krypton-88	Xenon-135m
	Xenon-138

**Table 3-1:** Radionuclides to be taken into account in the detailed assessment of the activity of radioactive noble gasses discharged with vent air

(3) The detection limit for the determination of the individual nuclides specified in para. 2 shall not exceed a value of  $1 \times 10^3$  Bq/m<sup>3</sup> with respect to xenon-133. Any undetected nuclides of **Table 3-1** shall be listed with the corresponding value of the decision thresholds and detection limits achieved in the individual measurements with the measurement equipment.

(4) If the measurement specified in para. 2 detects xenon-133 with an activity concentration exceeding  $1 \times 10^3$  Bq/m<sup>3</sup>, however no krypton-85, then, after a decay period of at least two days, a second analysis of the sample shall be performed with regard to determining the activity concentration of krypton-85.

(5) In addition to sampling in quarterly intervals, further representative samples shall, without delay, be taken and analyzed if the threshold value specified in Section 3.2.1 para. 1 is reached and registers for the duration exceeding 30 minutes. For as long as this threshold value continues to register, a sample shall be taken at least every 24 hours and its nuclide composition determined without delay.

(6) In the case of non-continuous sampling, the nuclide composition shall be assumed as being constant in the interim period between two consecutive samplings and at the level of the second measurement.

(7) As an alternative to the requirements specified under paras. 2 through 6, the activity of discharged radioactive noble gases may also be determined by continuous nuclide-specific measurements. The detailed assessment shall be based on the nuclide spectra determined in daily intervals. When evaluating the daily nuclide spectra, the detection limit of the measurement equipment shall not exceed a value of  $1 \times 10^3 \text{ Bq/m}^3$  for xenon-133.

(8) Any additional radioactive noble gas nuclides verified in the stack discharge shall individually be recorded in the report form (cf. **Figure 8-1**) under the heading "Other noble gasses".

### 3.3 Radionuclides Bound to Aerosol Particles

#### 3.3.1 Continuous measurement

(1) The radionuclides bound to aerosol particles discharged with vent air shall be monitored continuously. This requires that the radionuclides bound to aerosol particles shall be continuously accumulated from a partial air stream by deposition on a high-efficiency particulate air filter of at least Filter Class E12 in accordance with DIN EN 1822-1; the activity of the high-efficiency particulate air filter shall be measured during accumulation. From this measurement value the activity concentration shall be determined and shall be documented.

(2) The measurement equipment shall be designed such that, assuming a previously uncontaminated high-efficiency particulate air filter and a short-time exposure to a cesium-137 equivalent with a time integral of  $4 (\text{Bq/m}^3) \times h$ , the detection limit for the display of the measurement parameter "Activity on the filter" or "Increase of activity on the filter" will be exceeded in no more than one hour.

#### Note:

The requirements specified regarding the detection limit apply to the plant independent verification of the equipment characteristics.

(3) The high-efficiency particulate air filter shall be monitored for an activity level the exceedance of which would indicate that the filter must be exchanged. At this level it shall still be possible at a nominal volumetric flow of the vent air and a corresponding filter loading to be able to detect a discharge of  $5 \times 10^7 \text{ Bq}$  within one hour with a measurement uncertainty of less than 20 %.

(4) If the design of the measurement equipment for monitoring the discharge of radionuclides bound to aerosol particles does not provide for redundancy, the respective discharge shall be estimated for the duration of any outage duration of this measurement equipment; given a known volumetric flow of vent air, the estimation shall be based on some other permanently installed instrumentation, e.g., for monitoring the room atmosphere. The outage duration may not exceed a time period of 3 days.

(5) The requirement for a continuous measurement may be dispensed with, provided,

- a) the radionuclides bound to aerosol particles are retained by filtering the entire vent air with high-efficiency particulate air filters of at least Filter Class E12 in accordance with DIN EN 1822-1 and the functional capability of the retaining equipment is monitored, or
- b) a continuous measurement of the activity discharge from radioactive gaseous iodine is performed as specified in Section 3.4.1.

#### 3.3.2 Detailed assessment

(1) The activity of radionuclides bound to aerosol particles discharged with vent air shall be subjected to a detailed as-

essment. This requires that these substances are continuously accumulated by deposition on a high-efficiency particulate air filter of at least Filter Class E12 in accordance with DIN EN 1822-1.

(2) The accumulation period shall not exceed one week; the time elapsed between start of accumulation and start of measurement shall be accounted for by applying a corresponding correction for radioactive decay.

(3) The high-efficiency particulate air filters shall be analyzed by gamma spectrometric measurements within two days after removal of the filter. In this context, the radionuclides listed in **Table 3-2** shall be taken into account.

(4) The high-efficiency particulate air filter specified under para. 1 shall be analyzed without delay whenever the threshold value specified under Section 3.2.1 para. 1 is reached and has registered for the duration of more than 30 minutes.

(5) The detection limit of the measurement equipment for determining the activity concentration shall not exceed  $3 \times 10^{-2} \text{ Bq/m}^3$  with respect to cesium-137. Any undetected radionuclides of **Table 3-2** shall be listed with the value of the decision thresholds and detection limits achieved in the individual measurement with the measurement equipment.

<i>Radionuclides</i>	
Chromium-51	Silver-110m
Manganese-54	Antimony-124
Cobalt-58	Antimony-125
Iron-59	Iodine-131
Cobalt-60	Cesium-134
Zinc-65	Cesium-137
Zirconium-95	Barium-140
Niobium-95	Lanthanum-140
Ruthenium-103	Cerium-141
Ruthenium-106	Cerium-144

**Table 3-2:** Radionuclides to be taken into account in the detailed assessment of the activity of radionuclides bound to aerosol particles discharged with vent air

(6) Any additional radionuclides bound to aerosol particles verified in the stack discharge shall individually be recorded in the report form (cf. **Figure 8-1**) under the heading "Other  $\gamma$ -radiating radionuclides" or "Other  $\alpha$ -emitting radionuclides".

### 3.4 Radioactive Gaseous Iodine

#### 3.4.1 Continuous measurements

(1) The radioactive gaseous iodine discharged with vent air shall be monitored continuously. This requires that the radioactive iodine is continuously accumulated from a partial air stream on an iodine filter and that the filter is measured during accumulation for the deposited activity of iodine-131 (reference nuclide). The activity concentration shall be determined from this measurement value and shall be recorded.

(2) The measurement equipment shall be designed such that, assuming a previously uncontaminated iodine filter and a short-time exposure to iodine-131 with a time integral of  $2 (\text{Bq/m}^3) \times h$ , the display of the measurement parameter "Activity on the filter" or "Increase of activity on the filter" will exceed the detection limit in no more than one hour.

#### Note:

The requirements specified regarding the detection limit apply to the plant independent verification of the equipment characteristics.



(3) The iodine filter shall be monitored for an activity level the exceedance of which would indicate that the filter must be exchanged. At this level it shall still be possible at a nominal volumetric flow of vent air and a corresponding filter loading to be able to detect a discharge of  $1 \times 10^6$  Bq within one hour with a measurement uncertainty of less than 20 %.

(4) In order to prevent any falsification of the measurement values, a high-efficiency particulate air filter of at least Filter Class E12 in accordance with DIN 1822-1 shall be installed upstream of the iodine filter.

(5) Separation efficiency and loading capacity of the filters shall be taken into account both for elementary iodine and for organically bound iodine when choosing the sorption materials. The iodine sorbents used shall be characterized by a low adsorption for noble gasses.

**Note:**

The separation efficiency with respect to organically bound iodine is usually determined using methyl iodide as reference substance.

(6) If low licensed limit values prevent performing a continuous measurement of the discharge of iodine-131 with the measurement equipment specified under paras. 1 through 5, application of a plant-specific monitoring procedure is permissible.

### 3.4.2 Detailed Assessment

(1) The radioactive gaseous iodine discharged with the vent air shall be subjected to a detailed assessment. This requires that the radioactive gaseous iodine is accumulated by continuous deposition on an iodine filter.

(2) Separation efficiency and loading capacity of the iodine filters shall be taken into account both for elementary iodine and for organically bound iodine when choosing the filters.

(3) In order to prevent any falsification of the measurement values, a high-efficiency particulate air filter of at least Filter Class E12 in accordance with DIN EN 1822-1 shall be installed upstream of the iodine filter; this high-efficiency particulate air filter may be the same one as the one specified under Section 3.3.2

(4) The accumulation period shall not exceed one week; the time elapsed between start of accumulation and start of measurement shall be accounted for by applying a corresponding correction for radioactive decay.

(5) The activity of iodine-131 shall be determined by gamma spectrometric measurements within one day after taking the sample.

(6) The high-efficiency particulate air filter and the iodine filter shall be analyzed without delay whenever the threshold value specified under Section 3.2.1 para. 1 is reached and has registered for the duration of more than 30 minutes.

(7) With regard to the detailed assessment of the activity of radioactive iodine, the detection limit of the measurement equipment shall not exceed  $2 \times 10^{-2}$  Bq/m<sup>3</sup> with respect to the reference nuclide iodine-131.

(8) The detailed assessment of the activity of discharged radioactive iodine shall, preferably, be carried out as specified in paras. 1 through 7. Alternatively, it may be carried out as specified in paras. 9 through 13, provided, one, that the activity concentration of iodine-131 in the primary cooling circuit is less than  $1 \times 10^5$  Bq/m<sup>3</sup> and, two, that emissions not accounted for by this procedure, e.g., from experiments, are verified as being negligibly small.

(9) With regard to determining the discharged activity of iodine, representative water samples of the primary cooling circuit shall be taken in weekly intervals.

(10) The activity of iodine-131 in the representative water samples shall be determined by gamma spectrometric measurements within one day after the samples were taken. A corresponding correction for radioactive decay shall be applied.

(11) The detailed assessment of the radioactive iodine discharged with stack vent air shall basically be performed by multiplying the determined activity concentration of radioactive iodine in the primary cooling circuit by one-tenth (typical for research reactors) of the primary coolant volume that has evaporated during the period analyzed in the detailed assessment. It is permissible, alternatively, to base this detailed assessment of the radioactive iodine discharged with stack vent air on an experimentally determined coefficient accounting for the transfer of radioactive iodine from the primary cooling circuit to the stack vent air.

(12) Whenever the threshold value under Section 3.2.1 para. 1 is reached and has registered for the duration of more than 30 minutes, representative water samples from the primary cooling circuit shall, without delay, be taken and analyzed.

(13) The detection limit of the measurement equipment for performing the measurement specified under para. 10 shall, when performing the measurement on a sample of demineralized water, not exceed a value of  $4 \times 10^3$  Bq/m<sup>3</sup> for the reference nuclide iodine-131.

(4) Additionally iodine isotopes detected in the vent stack exhaust air in addition to iodine-131 shall be reported individually in the report form (cf. **Figure 8-1**) under "Other  $\alpha$ -emitting radionuclides".

## 3.5 Tritium

### 3.5.1 Light water reactors

(1) The activity discharge of tritium with vent air in the chemical form of water shall be monitored. This requires continuously accumulating air samples.

(2) The samples shall be analyzed for the activity of tritium in quarterly intervals. This analysis may be carried out on the individual samples specified under para. 1 or on a representative mixture sample.

(3) The analysis procedure shall be able to detect a tritium activity concentration as low as  $1 \times 10^3$  Bq/m<sup>3</sup> in the vent air.

(4) If the type of sampling requires that the temperature and humidity of the vent air must be taken into account, then these parameters shall be determined in monthly intervals.

(5) If molecular sieves are used to collect tritium, then a possible falsification of the measurement results by residual activity shall be taken into account. Once used molecular sieves should not be used a second time. However, if repeated use is intended, then, prior to deployment, the used molecular sieve shall be cleared of any residual water and shall be reactivated by subjecting it to a four hour long rinsing process in a stream of inert gas at a temperature of 400 °C.

(6) As an alternative to the requirements specified under paras. 1 through 5, the procedure described under paras. 7 through 9 may be used.

(7) With regard to the detailed assessment of the activity discharge of tritium, the activity concentration of tritium in the pool water shall be measured once a year.

(8) The activity discharge from tritium shall be calculated by multiplying the activity concentration of tritium determined for the sample with the amount of annually evaporated pool water.

(9) The detection limit for the measurement of the activity concentration of tritium in the pool water shall not exceed a value of  $4 \times 10^4$  Bq/m<sup>3</sup>.

(10) If a light water reactor is equipped with an additional heavy water tank the tritium inventory of which could exceed  $1 \times 10^{14}$  Bq, then the requirements under Section 3.5.2 shall be fulfilled.

### 3.5.2 Heavy water reactors

(1) The activity discharge from tritium with vent air shall be monitored continuously with respect to a threshold value. The detailed assessment shall be performed as specified under Section 3.5.1 paras. 1 through 5.

(2) The measurement range of the measurement equipment shall enable monitoring discharge rates between  $5 \times 10^7$  Bq/h and  $5 \times 10^{11}$  Bq/h depending on the nominal volumetric flow of the vent air.

(3) The detection limit of the measurement equipment shall not exceed a value of  $2 \times 10^3$  Bq/m<sup>3</sup>.

(4) In order to prevent a falsification of the measurement values, a high-efficiency particulate air filter of at least Filter Class E12 in accordance with DIN EN 1822-1 shall be installed upstream of the measurement equipment.

(5) The volumetric flow of the measurement air and of the counter gas shall be kept constant within the permissible deviation of  $\pm 15\%$ ; they shall each be monitored by a flow rate meter with respect to their respective upper and a lower threshold values.

### 3.6 Radioactive Strontium

(1) The radioactive strontium discharged with vent air shall be monitored by continuously accumulating the strontium by deposition on a high-efficiency particulate air filter of at least Filter Class E12 in accordance with DIN EN 1822-1 from a partial air stream of the vent air. This high-efficiency particulate air filter may be the same one as the one specified under Section 3.3.2.

(2) The analysis for strontium-89 and strontium-90 shall be performed in quarterly intervals on mixture samples that may be created from the high-efficiency particulate air filters exposed in that particular time period. The time elapsed between start of sampling and start of measurement shall be accounted for applying a corresponding correction for the radioactive decay of strontium-89.

(3) The activity of radioactive strontium isotopes discharged with vent air shall be subjected to a detailed assessment. The detection limit regarding the detailed assessment of the discharged activity of strontium-89 and strontium-90 shall not exceed a value of  $1 \times 10^{-3}$  Bq/m<sup>3</sup>.

(4) The detailed assessment specified under paras. 1 through 3 may be dispensed with, provided, one, the activity concentration of lanthanum-140 (as reference nuclide) from the detailed assessment of radionuclides bound to aerosol particles under Section 3.3.2 does not exceed a value of  $2 \times 10^{-2}$  Bq/m<sup>3</sup>, two, the discharge of strontium-89 and strontium-90 from carrying out experiments is verified as being negligibly small.

### 3.7 Alpha Emitters

(1) The alpha emitting radioactive substances (alpha emitters) discharged with vent air shall be monitored by continuously accumulating the alpha-emitters by deposition on a high-efficiency particulate air filter of at least Filter Class E12 in accordance with DIN EN 1822-1 from a partial air stream of the vent air. This high-efficiency particulate air filter may be the same one as the one specified under Section 3.3.2.

(2) The nuclide-specific analysis for alpha emitters shall be performed in quarterly intervals on mixture samples that may

be created from the high-efficiency particulate air filters exposed in that particular time period.

(3) The activity of alpha emitters discharged with the vent air shall be subjected to a detailed assessment. In this assessment the radionuclides listed in **Table 3-3** shall be taken into account. The detection limit of the measurement equipment shall not exceed a value of  $5 \times 10^{-3}$  Bq/m<sup>3</sup> with respect to americium-241. Any undetected radionuclides of **Table 3-3** shall be listed with the value of the decision thresholds and detection limits achieved in the individual measurement with the measurement equipment. The nuclide pair plutonium-238 and americium-241 as well as the pair plutonium-239 and americium-240 may be summed up together in the detailed assessment.

(4) Any additional alpha-emitting radionuclides verified in the vent stack air shall be individually recorded in the report form (cf. **Figure 8-1**) under the heading "Other  $\alpha$ -emitting radionuclides".

(5) The detailed assessment specified under paras. 1 through 3 may be dispensed with, provided, the total alpha activity concentration in the primary cooling circuit does not exceed a value of  $1 \times 10^3$  Bq/m<sup>3</sup> and the discharge of alpha emitters from carrying out experiments is verified as being negligibly small. The total alpha activity concentration shall be determined in quarterly intervals from representative mixture samples.

<i>Radionuclides</i>	
Uranium-234 <sup>1)</sup>	Americium-241
Plutonium-238	Curium-242
Plutonium-239	Curium-244
Plutonium-240	
<sup>1)</sup> Used instead of curium-242 and curium-244 in case of research reactors with highly enriched nuclear fuel	

**Table 3-3:** Radionuclides to be taken into account in the detailed assessment of the activity of alpha emitters discharged with vent air

### 3.8 Carbon-14

(1) The carbon-14 discharged with vent air in the chemical form of carbon dioxide shall be monitored. For this purpose, carbon-14 samples shall be accumulated continuously. The analysis for carbon-14 shall be performed in quarterly intervals by evaluating mixture or cumulative samples. The analysis procedure shall be able to detect a carbon-14 activity concentration of as low as 5 Bq/m<sup>3</sup> in the vent air.

(2) The monitoring specified under para. 1 may be dispensed with, provided, the activity discharge of carbon-14 is assessed in detail by another determination procedure, e.g. one that is based on calculating the production rate of carbon 14.

### 3.9 Sampling

(1) The location and procedure of sampling pipes shall be chosen such that the samples taken there are representative for emission monitoring. The objective must be that a homogeneous mixture of the vent air has been achieved in the region where sampling is carried out.

(2) The volumetric flow of the partial air stream directed out of the vent air shall normally not be less than one thousands of the nominal volumetric flow rate of the vent air.

#### Note:

Details regarding sampling are specified in DIN ISO 2889.

(3) The sampling pipes shall be designed, routed and fabricated of such materials that aerosols and other gaseous radioactive iodine compounds are retained as little as possible.

Note:

Details regarding the design are specified in DIN ISO 2889.

(4) The sampling equipment shall be designed or housed such that its temperature cannot fall below the dew point.

(5) Selection and storage of the adsorption material for filters shall take ageing effects of the material into account. The temperature shall be kept within the specified range.

(6) In the design of a filter bracket, it shall be considered

- a) that during operation its leak-tightness is such that the volumetric flow of leakage air is negligibly small relative to the partial volumetric flow for sampling,
- b) that any damage of the filter in the area of the filter gasket is avoided,
- c) that any bypass flow around the filter is avoided,
- d) that the filter can be changed easily and, to a large extent, without danger of contamination,
- e) that it is corrosion resistant and easy to decontaminate.

(7) In the case of non-continuous sampling, the point in time and duration of the sampling shall be chosen such that the individual samples are representative for the amounts of radioactive substances discharged between two consecutive samplings.

(8) The sampling equipment for the continuous sampling of radionuclides bound to aerosol particles shall be designed such that during specified normal operation a spectrum of particles with aerodynamically equivalent diameters in the range between 0.1  $\mu\text{m}$  and 20  $\mu\text{m}$  is covered. The overall dissipation factor of the actual sampling equipment shall be determined by one of the following procedures:

- a) The overall dissipation factor of radionuclides bound to aerosol particles may be determined using test aerosol particles where the particle size of the specific material type (number and mass of the test aerosol particles) has a median value with an aerodynamically
- b) equivalent diameter of approximately 1  $\mu\text{m}$  with a geometric standard deviation between 2 and 3. These test aerosol particles shall be fed into the vent air duct and the overall dissipation factor determined from the amount supplied and the amount found on the accumulating medium.
- c) The overall dissipation factor of radionuclides bound to aerosol particles may be determined by feeding the test aerosol particles into one of the sampling probes and calculating the pipe factor. In this case, the other parameters required for

determining the overall dissipation factor shall be determined by individual measurements or calculations.

d) The overall dissipation factor of radionuclides bound to aerosol particles may be determined by comparing the activity concentration measured directly in the vent air stack with the activity concentration determined from the measurement values of the accumulating and measurement equipment.

(9) The overall dissipation factor shall be determined

- a) during commissioning of the sampling equipment,
- b) after any alteration of the sampling equipment that could essentially influence the overall dissipation factor, and
- c) regularly after every ten years.

(10) The overall dissipation factor determined as specified under para. 9 shall be taken into account in the detailed assessment of the activity discharge of radionuclides bound to aerosol particles.

Notes:

(1) Aside from the gamma-radiating radionuclides, the radionuclides bound to aerosol particles also comprise the strontium isotopes Sr-89 and Sr-90 and the alpha-emitting radionuclides.

(2) The detailed assessment includes the overall loss factor from calculating the activity disposal, as well as the decision threshold and the lower detection limit.

### 3.10 Non-central Monitoring of Emissions

#### 3.10.1 General requirements

In research reactors radioactive substances may be produced in rooms and parts of the facility or may be transported to locations that are not connected to the central vent air stack. The discharge path of these radioactive substances ("non-central monitoring of emissions") shall be properly documented for the individual facility or task.

#### 3.10.2 Monitoring

The discharge of radioactive substances from the facilities or during the tasks specified under Section 3.10.1 shall be monitored. This requires that representative monthly samples are taken from suitable locations and at times that are representative for the respective operating period; these samples shall be subjected to a nuclide-specific analysis. The annual activity discharge shall be estimated on the basis of this analysis and shall be documented in the annual report.

Note:

The essential requirements of Section 3 are collated in **Table 3-4**.

Measurement Task	Measurement Procedure	Measurement Range	Detection Limit	Reference Nuclide	Remarks
<b>Noble gasses</b>					
Continuous measurement	total $\beta$ -activity	1)	$1 \times 10^4$ Bq/m <sup>3</sup>	Xe-133	The threshold value is oriented on the value of the licensed discharge. If Xe-133 but no Kr-85 is detected, then the measurement for Kr-85 shall be repeated after a period of at least two days.
Detailed assessment	nuclide specific $\gamma$ - activity		$1 \times 10^3$ Bq/m <sup>3</sup>	Xe-133	
<b>Radionuclides bound to aerosol particles</b>					
Continuous measurement	total $\beta$ -activity or total $\gamma$ -activity		$4$ (Bq/m <sup>3</sup> ) $\times$ h	Cs-137	The continuous measurement may be dispensed with, provided, a continuous measurement of radioactive iodine is performed or the radionuclides bound to aerosol particles are retained by filtering the entire exhaust air and the proper functioning of the retaining equipment is monitored.
Detailed assessment	deposition on filter		$2 \times 10^{-2}$ Bq/m <sup>3</sup>	Co-60	
<b>Iodine</b>					
Continuous measurement	$\gamma$ - activity		$2$ (Bq/m <sup>3</sup> ) $\times$ h	I-131	
Detailed assessment	deposition on filter		$2 \times 10^{-2}$ Bq/m <sup>3</sup>	I-131	Detailed assessment on the basis of evaporation if the activity concentration of I-131 in the water sample is less than $1 \times 10^5$ Bq/m <sup>3</sup>
	sampling of water		$4 \times 10^3$ Bq/m <sup>3</sup>	I-131	
<b>Tritium</b>					
<b>Light water research reactors</b>					
Detailed assessment	accumulation in collector		$1 \times 10^3$ Bq/m <sup>3</sup>	H-3	Alternative measurements in the pool water are permissible
	sampling of water		$4 \times 10^4$ Bq/m <sup>3</sup>	H-3	
<b>Heavy water research reactors</b>					
Continuous measurement	$\beta$ -activity	$5 \times 10^7$ Bq/h to $5 \times 10^{11}$ Bq/h	$2 \times 10^3$ Bq/m <sup>3</sup>	H-3	
Detailed assessment	accumulation in collector		$1 \times 10^{-3}$ Bq/m <sup>3</sup>	H-3	
<b>Strontium</b>					
Detailed assessment	deposition on filter		$1 \times 10^{-3}$ Bq/m <sup>3</sup>	La-140	The detailed assessment may be dispensed with, provided, one, the activity concentration of La-140 (reference nuclide) from the detailed assessment of radionuclides bound to aerosol particles does not exceed $2 \times 10^{-2}$ Bq/m <sup>3</sup> and, two, the discharge of Sr-89 and Sr-90 from carrying out experiments is verified as being negligibly small.
<b>Alpha emitters</b>					
Detailed assessment	deposition on filter		$5 \times 10^{-3}$ Bq/m <sup>3</sup>	Am-241	The high-efficiency particulate air filter shall basically be analyzed for alpha emitters, cf. Section 3.7 para. 2.
	sampling of water		$1 \times 10^3$ Bq/m <sup>3</sup>	Am-241	The detailed assessment may be dispensed with, provided, one, the total alpha activity concentration of alpha emitters in the primary coolant circuit does not exceed $1 \times 10^{-3}$ Bq/m <sup>3</sup> and, two, the discharge of alpha emitters from carrying out experiments is verified as being negligibly small.
<b>Carbon-14</b>					
Detailed assessment	accumulation in collector		$5$ Bq/m <sup>3</sup>		Accumulation of carbon dioxide. Other determination procedures are permissible.
1) Upper limit of measuring range shall be at least one tenth of the annual licensed limit value averaged over 24 h.					

**Table 3-4:** Monitoring of the discharge of radioactive substances with exhaust air during specified normal operation

## 4 Monitoring the Radioactive Substances Discharged with Vent Air during Design Basis Accidents

### 4.1 General Requirements

(1) During and after design basis accidents the discharged radioactive substances shall be determined according to kind and activity in accordance with the requirements specified in this Section 4. With regard to the measuring procedures and the radiological relevance of the discharged radioactive substances, the following nuclides and nuclide groups shall be differentiated between:

- a) radioactive noble gasses,
- b) radionuclides bound to aerosol particles,
- c) radioactive gaseous iodine,
- d) tritium.

(2) If it is verified by design basis accident analyses that the design basis accident related activity discharge from individual or all of the nuclide groups specified under para. 1

- a) cannot lead to an exceedance of the licensed annual limit values and
- b) will be monitored during a design basis accident by the measurement equipment of specified normal operation and this monitoring is in accordance with the requirements for the measurement equipment for monitoring the discharge of radioactive substances with vent air,

then, no additional measurement equipment for the respective nuclide groups is required.

(3) The continuous or non-continuous sampling and measurements necessary for monitoring the discharge of radioactive substances shall normally be carried out in a partial air stream of the vent air.

(4) The volumetric flow of vent air shall be continuously measured and recorded.

(5) The volumetric flows of the partial air streams of the vent air shall be monitored; a drop of the volumetric flows of the partial air streams below a threshold value shall set off an alarm in the display area of the control room dedicated to emission monitoring.

(6) If it cannot be precluded for the measurement equipment for monitoring the discharge with stack vent air that they might fail due to effects from design basis accidents (e.g., fire), it shall be ensured that alternative monitoring can be carried out without delay, e.g., non-continuous sampling. This requires that corresponding sampling points are provided, e.g., in the exhaust gas duct or in the base of the exhaust gas stack.

(7) With respect to the analysis of gaseous samples, of the aerosol and the iodine filters, suitable procedures and measurement equipment in the laboratory shall be provided taking the maximum expected activity of the samples into account.

### 4.2 Radioactive Noble Gasses

#### 4.2.1 Continuous measuring

(1) The activity discharge rate of the radioactive noble gasses discharged with vent air shall be continuously determined by measuring the activity concentration in the vent air and measuring the vent air's volumetric flow.

(2) The total beta activity concentration of the radioactive noble gasses shall be determined from a measurement of the total beta activity.

(3) For the purpose of measuring the activity concentration, one filter with a retention level of at least 90 % for elementary iodine and one high-efficiency particulate air filter of at least

Filter Class E12 in accordance with DIN EN 1822-1 shall be installed upstream of the measurement chamber to prevent its contamination.

(4) The detection limit of the measurement equipment for measuring the activity concentration shall not be higher than one thousands of the licensed annual limit value with respect to the vent air volume discharged in a 24 h period.

(5) Design basis accident analyses shall be performed in order to specify the end points of the measurement range. The resulting maximum activity concentration of radioactive noble gasses in the vent air multiplied by a safety margin of 10 shall normally still be within the measurement range of the measurement equipment.

(6) An activity measurement equipment for specified normal operation as specified under Section 3.2.1 may be used instead of the measurement equipment specified under para. 2, provided, the former is designed to be redundant and also fulfills the requirements of this Section 4.

#### 4.2.2 Detailed assessment

(1) The nuclide composition of radioactive noble gasses discharged with vent air shall be determined by gamma spectrometric measurements.

(2) In case the nuclide composition of radioactive noble gasses is determined non-continuously, representative samples shall basically be taken from the onset of a design basis accident on, as far as possible, in hourly intervals for as long as a design basis accident related release in exceedance of the licensed limit value for specified normal operation must be expected; these samples shall be analyzed without delay. It is permissible to take samples and perform nuclide-specific measurements in longer time intervals than one hour, provided, the measurement value at the noble gas measurement equipment specified under Section 4.2.1 indicates that no essential changes have occurred.

(3) In the case of a non-continuous determination of the nuclide composition, the activity discharge of individual radioactive noble gas nuclides shall be determined based on the activity concentration determined with the measurement equipment specified under Section 4.2.1 para. 2.

(4) The nuclide composition of radioactive noble gasses may also be determined by continuous nuclide-specific measurements.

#### 4.3 Radionuclides Bound to Aerosol Particles

(1) For as long as it must be assumed that a design basis accident related discharge of radionuclides bound to aerosol particles can occur that exceeds a licensed limit value for specified normal operation, the activity of the individual radionuclides bound to aerosol particles discharged with vent air shall, as far as possible, be determined in hourly intervals by gamma spectrometric measurements.

(2) For the purpose of determining the nuclide composition of the radionuclides bound to aerosol particles, these substances shall be continuously accumulated from a partial air stream by deposition on a high-efficiency particulate air filter of at least Filter Class E12 in accordance with DIN EN 1822-1. This sampling equipment may be the same one specified under Section 3.3.2 for the detailed assessment of radionuclides bound to aerosol particles during specified normal operation, provided, this equipment also fulfills the requirements of this Section 4.

(3) During accumulation of radionuclides bound to aerosol particles, the volumetric flow of the partial air stream shall be

measured, and any deviation by more than 20 % from its nominal value shall set off an alarm (in the control room).

(4) The high-efficiency particulate air filter specified under para. 2 shall normally, as far as possible, be evaluated without delay; the analyses for determining the activity of the alpha emitters and strontium isotopes discharged with vent air may be performed on cumulative samples after the end of the design basis accident.

#### 4.4 Radioactive Gaseous Iodine

(1) For as long as it must be assumed that a design basis accident related discharge of radioactive iodine might exceed the licensed limit value for specified normal operation, the activity of the individual nuclides of radioactive iodine discharged with vent air shall, as far as possible, be determined in hourly intervals by gamma spectrometric measurements.

(2) For the purpose of determining the nuclide composition of the radioactive iodine, these substances shall be continuously accumulated on an iodine filter. This sampling equipment may be the same as the one specified under Section 3.4.2 for the detailed assessment of radioactive iodine during specified normal operation, provided, this equipment also fulfills the requirements of this Section 4.

(3) In order to prevent any falsification of the measurement values, a high-efficiency particulate air filter of at least Filter Class E12 in accordance with DIN EN 1822-1 shall be installed upstream of the iodine filter; this high-efficiency particulate air filter may be the same one specified under Section 4.3 para. 2.

(4) During accumulation of radioactive iodine, the volumetric flow of the partial stream shall be measured, and any deviation by more than 20 % from its nominal value shall set off an alarm (in the control room).

#### 4.5 Tritium

(1) The discharge of tritium shall be monitored in heavy water reactors and in light water reactors that are equipped with additional heavy water tanks the tritium inventory of which could exceed a value of  $1 \times 10^{14}$  Bq.

(2) The activity discharge rate of tritium with vent air shall be determined continuously from the measurements of the activity concentration and of the volumetric flow of the vent air.

(3) In order to prevent any falsification of the measurement values, a high-efficiency particulate air filter of at least Filter Class E12 in accordance with DIN EN 1822-1 shall be installed upstream of the respective measurement equipment.

(4) The volumetric flow of the measurement air and of the counter gas shall be kept constant within a deviation of  $\pm 15$  %; they shall each be monitored by a flow rate meter with respect to their upper and the lower threshold values.

(5) The detection limit of the measurement equipment for monitoring the activity concentration shall not be higher than one thousandths of the licensed annual limit value with respect to the vent air volume discharged in a 24 h period.

(6) Design basis accident analyses shall be performed in order to specify the end points of the measurement range. The resulting maximum activity concentration of tritium multiplied by a safety factor of 10 shall normally still lie within the measurement range of the measurement equipment.

(7) The measurement equipment specified under Section 3.5.2 for monitoring tritium during specified normal operation may be used during design basis accidents, provided, it also fulfills the requirements of this Section 4.

## 4.6 Sampling

### 4.6.1 Radiation protection and the sampling points

(1) Sampling, transport of the sample and the procedure of the nuclide-specific measurements shall be designed and planned such that the effective dose shall not exceed a design reference level of 1 mSv per individual person and sampling.

(2) Sampling points that must be personally attended to shall be located and shielded such that the local dose rate at these locations shall not exceed the design reference level of 10 mSv/h, even for the maximum local dose rates resulting from the design basis accident analyses.

(3) Vent air channels leading out of the area protected against external events shall be equipped with connection possibilities within this protected area for the removal of samples.

### 4.6.2 Sampling equipment and procedures

(1) The sampling point and the sampling procedure shall normally be chosen such that the samples taken there are representative for the emission during a design basis accident. The objective must be to achieve a homogenous mixture of the vent air in the region where sampling is carried out.

(2) The sampling pipes for aerosols and iodine shall be designed, routed and of such a material that aerosols and gaseous iodine compounds are retained as little as possible.

Note:

Details regarding the respective design are specified in DIN ISO 2889.

(3) The sampling equipment shall be designed or housed such that its temperature cannot fall below the dew point.

(4) The selection of the adsorption material for the filters shall take ageing effects into account. The temperature shall be kept within the specified range.

(5) When selecting the adsorption material, the separation efficiency and loading capacity of the filters for elementary and organically bound iodine shall be taken into account. The iodine sorbents used shall be characterized by a low adsorption for noble gasses.

(6) The components of the aerosol and iodine filters shall be designed and arranged such

- a) that leak-tightness is ensured during operation and the volumetric flow of leakage air is negligibly small relative to the volumetric flow of the partial air for sampling,
- b) that any damage of the filter in the region of the filter gasket is avoided and that any bypass flow around the filter is impossible,
- c) that the filters can be easily changed,
- d) that all mechanical parts are corrosion resistant,
- e) that the respective installation can be flushed, e.g., for the removal of noble gasses.

(7) In the case of a non-continuous sampling, the nuclide composition shall be assumed as being constant in the interim period between two consecutive samplings and at the level of the second measurement. If an explicit statement going beyond the most recent sampling becomes necessary, the nuclide composition of the most recent sample may be used as long until a new sample becomes available.

## 5 Monitoring of Radioactive Substances Discharged with Water

### 5.1 Radioactively Contaminated Waste Water

#### 5.1.1 General requirements

(1) Radioactive waste water produced during operation of the reactor shall be collected in a waste water discharge tank prior to its discharge.

(2) In as far as the nuclear operating license for the reactor includes the handling of unsealed radioactive substances, e.g. in radiochemistry laboratories, the reactor operator shall be responsible for monitoring and supervising the radioactive waste water. The procedure specified under para. 1 shall be followed.

#### 5.1.2 Sampling

Before discharging any radioactive waste water, a sample representative of the entire contents of the waste water discharge tank shall be taken as basis for the decision measurement (cf. Section 5.1.3) and for the preparation of mixture samples (cf. **Appendix A**). For this purpose the entire contents of the tank shall be homogenized prior to sampling, e.g., by tank-to-tank pumping, by circulation or by stirring. The homogenization should be carried out for a length in accordance with the size of the tank, however, at least for 30 minutes. Prior to sampling, the sampling pipe shall be flushed with the homogenized water. One liter of the sample shall be used for the decision measurement and shall be stored as evidential sample for the duration of one year (one-liter sample). From the point in time of sampling until the end of the discharge procedure, no water shall flow into the waste water discharge tank.

#### 5.1.3 Decision measurement

(1) In order to enable a decision with respect to a discharge from the waste water discharge tank, an integral measurement of gamma radiation in the energy range above 60 keV shall be performed. If it must be assumed that, due to the handling of unsealed radioactive substances in accordance with Section 5.1.1 para. 2, pure beta emitters or alpha emitters are present in the waste water, an integral measurement of beta emission in the energy range above 0.1 MeV or an integral measurement of alpha emission in the energy range above 4 MeV is required. These measurements shall be performed as double determinations. The pulse rates determined from the integral measurements shall be specified as a cesium-137 equivalent for gamma sources, as a strontium-90/yttrium-90 equivalent for beta emitters, and as an americium-241 equivalent for alpha emitters.

(2) In the case of heavy water reactors and of light water reactors that are equipped with additional heavy water tanks the tritium inventory of which could exceed a value of  $1 \times 10^{14}$  Bq, additionally, a double determination of the activity concentration of tritium is required.

(3) The integral measurements specified under para. 1 shall be carried out in such a way that the integral measurement of gamma radiation covers a range of the cesium-137 equivalent between  $1 \times 10^4$  Bq/m<sup>3</sup> and  $1 \times 10^7$  Bq/m<sup>3</sup>, that the integral measurement of beta emissions covers a range of the strontium-90/yttrium-90 equivalent between  $1 \times 10^3$  Bq/m<sup>3</sup> and  $1 \times 10^6$  Bq/m<sup>3</sup>, and that of alpha emissions a range of the americium-241 equivalent between  $1 \times 10^3$  Bq/m<sup>3</sup> and  $1 \times 10^6$  Bq/m<sup>3</sup>. The measurement of the activity concentration of tritium specified under para. 2 shall cover a range between  $4 \times 10^4$  Bq/m<sup>3</sup> and  $4 \times 10^9$  Bq/m<sup>3</sup>.

#### Note:

The terms 'strontium-90/yttrium-90 equivalent' and 'americium-241 equivalent' are used analogously to the term 'cesium-137 equivalent' defined under Section 2 para.6.

(4) Alternatively to the requirements under para. 1, the gamma radiation may also be determined by nuclide-specific measurements. In this context, at least the radionuclides listed in Table 5-1 shall be taken into account. The detection limit of the measurement equipment for determining activity concentrations shall not exceed a value of  $1 \times 10^3$  Bq/m<sup>3</sup> for cobalt-60 when performing the measurement on a sample of demineralized water.

#### 5.1.4 Discharging procedure

(1) The water from the waste water discharge tank may only be pumped off if the cesium-137 equivalent does not exceed a value of  $5 \times 10^6$  Bq/m<sup>3</sup> and if the licensed discharge values or the discharge values specified by the authorities for the activity concentration and discharge are not exceeded and if the written confirmation has been issued by a radiological protection officer or by a person authorized by that officer.

(2) In case of a nuclide-specific determination of gamma radiation for the decision under para. 1, the maximum permissible nuclide-specific activity concentrations specified in accordance with Appendix VII Table 4 column 3 StrlSchV and the following equation shall be applied with a threshold value of  $c_s = 5 \times 10^6$  Bq/m<sup>3</sup>.

$$\frac{c_B}{c_S} \cdot \sum_{i=1}^n \frac{\bar{c}_i}{c_i} \leq 1 \quad (5-1)$$

#### Nomenclature

$c_B$  maximum permissible activity concentration in Bq/m<sup>3</sup> of the reference nuclide (cesium-137) in accordance with Appendix VII Table 4 column 3 StrlSchV

$c_S$  threshold value in Bq/m<sup>3</sup>

$\bar{c}_i$  activity concentration in Bq/m<sup>3</sup> of radionuclide, i, in the cooling medium

$c_i$  maximum permissible activity concentration in Bq/m<sup>3</sup> of radionuclide, i, in accordance with Appendix VII Table 4 column 3 StrlSchV

(3) During discharge the cesium-137 equivalent shall be continuously monitored by a measurement equipment for the integral measurement of gamma radiation. Both, the exceedance of a cesium-137 equivalent of  $5 \times 10^6$  Bq/m<sup>3</sup> as well as a failure of the measurement equipment shall be displayed and recorded in the control room. In these cases, the discharge procedure shall be automatically interrupted.

(4) The measurement range of the measurement equipment for the continuous measurement of the cesium-137 equivalent specified under para. 3 shall extend from  $1 \times 10^5$  Bq/m<sup>3</sup> to at least  $1 \times 10^7$  Bq/m<sup>3</sup>.

(5) The detection limit of the gamma measurement equipment for measuring the cesium-137 equivalent specified under para. 3 shall not exceed the lower limit of the measurement range specified under para. 4 for a measurement duration of one hour.

#### 5.1.5 Detailed assessment

##### 5.1.5.1 Gamma sources

(1) With regard to the detailed activity assessment and, provided, the procedure under para. 2 is not applied, one part of the sample taken prior to discharging shall be subjected to a gamma-spectroscopic analysis within the calendar week following the discharge. In this context, at least the radionuclides listed in **Table 5-1** shall be taken into account. The detection limit of the measurement equipment for determining the activity concentration shall not exceed a value of  $1 \times 10^3$  Bq/m<sup>3</sup> for cobalt-60 when performing the measurement on a sample of demineralized water.

Within the framework of the gamma spectrometric analyses it shall be checked whether there is a plant specific occurrence of other radionuclides not listed in **Table 5-1**. If any of these are verified, only those radionuclides shall be included in the detailed assessment the radioactive half-life of which is longer than 8 days.

<b>Radionuclides</b>	
Chromium-51	Silver-110m
Manganese-54	Antimony-124
Cobalt-58	Antimony-125
Iron-59	Iodine-131
Cobalt-60	Cesium-134
Zinc-65	Cesium-137
Zirconium-95	Barium-140
Niobium-95	Lanthanum-140
Ruthenium-103	Cerium-141
Ruthenium-106	Cerium-144

**Table 5-1:** Gamma-radiating radionuclides to be taken into account in the detailed assessment of radioactive substances discharged with water

(2) In case a mixture sample as specified under Section 5.1.2 is created for use in the detailed assessment, the selection of the accumulation and evaluation time period shall take the required detection limits, the radiological half-lives of the expected nuclides and the licensed discharge limit values into account.

#### 5.1.5.2 Radioactive strontium

Quantity-proportional quarterly mixture samples shall be prepared and shall be analyzed with regard to their content of strontium-89 and strontium-90 within the calendar month following their preparation. The detection limit of the procedure for determining the activity concentration shall not exceed a value of  $5 \times 10^2$  Bq/m<sup>3</sup>.

#### 5.1.5.3 Alpha emitters

(1) Quantity-proportional twelve-month mixture samples shall be prepared and shall be analyzed with regard to their content of alpha emitters (total alpha activity) within the calendar quarter following their preparation. The detection limit of the procedure for determining the total alpha activity concentration shall not exceed a value of  $2 \times 10^2$  Bq/m<sup>3</sup> with respect to americium-241. If the analysis of a sample results in a value for the total alpha activity concentration exceeding  $1 \times 10^3$  Bq/m<sup>3</sup>, this sample shall be analyzed with respect to its content of individual alpha emitters. In this context, the radionuclides listed in **Table 5-2** shall be taken into account. The detection limit of the procedure for determining the activity concentration of the individual nuclides shall not exceed a value of 50 Bq/m<sup>3</sup> with respect to americium-241. In the detailed assessment, the nuclides plutonium-239 and plutonium-240 may be summed up together.

(2) Additional radionuclides verified in the waste water shall be individually recorded in the report form (cf. **Figure 8-2**) under the heading "Other  $\alpha$ -emitting radionuclides".

#### 5.1.5.4 Tritium

(1) Quantity-proportional twelve-month mixture samples shall be prepared and shall be analyzed with regard to their content of tritium within the calendar quarter following their preparation.

<b>Radionuclides</b>	
Uranium-234 <sup>1)</sup>	Americium-241
Plutonium-238	Curium-242
Plutonium-239	Curium-244
Plutonium-240	

<sup>1)</sup> Used instead of curium-242 and curium-244 in the case of research reactors with highly enriched nuclear fuel

**Table 5-2:** Alpha-emitting radionuclides to be taken into account in the detailed assessment of radioactive substances discharged with water

(2) In the case of heavy water reactors and of light water reactors that are equipped with additional heavy water tanks the tritium inventory of which could exceed a value of  $1 \times 10^{14}$  Bq, quantity-proportional monthly mixture samples shall be prepared and shall be analyzed with regard to their tritium content within the calendar week following their preparation.

(3) The detection limit of the procedure for determining the activity concentration shall not exceed a value of  $4 \times 10^4$  Bq/m<sup>3</sup>.

#### 5.1.5.5 Iron-55 and nickel-63

Within the first three months after preparation of the twelve-month mixture sample, its content of iron-55 and nickel-63 shall be determined. The detection limit of the procedure for determining the activity concentration shall not exceed a value of  $2 \times 10^3$  Bq/m<sup>3</sup>.

#### 5.1.5.6 Other radionuclides

If it cannot be excluded, due to a nuclear operating license as specified under Section 5.1.1 para. 2 that radionuclides can get into a waste water discharge tank that cannot be determined by the measurement procedures specified for detailed assessment in the previous sections, special methods shall be specified in the operating manual for a detailed assessment of these radionuclides.

#### 5.1.5.7 Correction for radioactive decay

The activity concentrations of the radionuclides verified in the detailed assessment measurements of mixture samples shall be corrected to the middle of the accumulation time period corresponding to their respective half-life values.

#### 5.2 Cooling Water (Intermediate Cooling Circuits)

(1) Intermediate cooling circuits shall preferably be monitored by measurement equipment for a continuous integral measurement of gamma radiation.

(2) If a continuously measuring monitoring equipment as specified under para. 1 is not available, a sample shall be taken from each intermediate cooling circuit in weekly intervals; the cesium-137 equivalent of each sample shall be determined within the calendar week following sampling by measuring the gamma radiation in the energy range above 60 keV.

(3) If a continuously measuring monitoring equipment as specified under para. 1 is available, sampling of these intermediate cooling systems is required only in quarterly intervals; the cesium-137 equivalent of each sample shall be determined within the calendar week following sampling by measuring the gamma radiation in the energy range above 60 keV.

(4) The measurement range of the gamma measurement equipment for the continuous measurement of the cesium-137



equivalent specified under para. 1 shall extend from  $4 \times 10^4 \text{ Bq/m}^3$  to at least  $1 \times 10^7 \text{ Bq/m}^3$ .

(5) The detection limit of the continuously measurement equipment specified under para. 1 – given a measurement duration of 10 minutes – shall not exceed the lower limit of the measurement range specified under para. 4.

(6) The threshold value for the cesium-137 equivalent of the monitoring equipment specified under para. 1 shall be adjusted to  $4 \times 10^5 \text{ Bq/m}^3$ . Any exceedance of this threshold value shall set off an alarm in the control room and shall be recorded.

(7) The measurement range of the measurement equipment for measuring the cesium-137 equivalent when analyzing the samples specified under paras. 2 and 3 shall extend from  $1 \times 10^4 \text{ Bq/m}^3$  to at least  $1 \times 10^7 \text{ Bq/m}^3$ .

(8) The respective intermediate cooling circuit should be shut down, either, if the cesium-137 equivalent at the monitoring equipment specified under para.1 exceeds a value of  $4 \times 10^5 \text{ Bq/m}^3$  or if the analysis of one of the samples taken as specified under paras. 2 and 3 results in a cesium-137 equivalent exceeding a value of  $1 \times 10^4 \text{ Bq/m}^3$ . Otherwise, without delay, a sample shall be taken from the corresponding tertiary cooling system and its gamma count rate promptly determined by measuring the gamma radiation in the energy range above 60 keV as a cesium-137 equivalent using the integral gamma measurement equipment specified under para. 7.

(9) If the cesium-137 equivalent verified for the sample taken as specified under para. 8 sentence 2 exceeds  $1 \times 10^4 \text{ Bq/m}^3$  and the activity concentration in the corresponding secondary cooling circuit is less or equal to  $4 \times 10^5 \text{ Bq/m}^3$ , a further sample shall be taken in weekly intervals from the tertiary cooling system and its gamma count rate determined within 24 hours by measuring the gamma radiation in the energy range above 60 keV as a cesium-137 equivalent using the integral gamma measurement equipment specified under para. 7. If the activity concentration in the corresponding intermediate cooling circuit

exceeds  $4 \times 10^5 \text{ Bq/m}^3$ , samples shall be taken from the tertiary cooling system in daily intervals and shall be analyzed without delay.

(10) The corresponding intermediate cooling circuit shall be shut down without delay if the analysis of one of the samples specified under paras. 8 and 9 taken from the tertiary cooling system results in a cesium-137 equivalent exceeding a value of  $1 \times 10^4 \text{ Bq/m}^3$ .

#### Notes:

(1) To illustrate the requirements of this safety standard, **Figure 5-1** shows an exemplary schematic of the systems required to be monitored together with the corresponding measurement equipment and sampling points. The requirements regarding the monitoring equipment are collated in **Tables 5-3** and **5-4**.

(2) The requirements of this Section 5 and those of Section 6 regarding stationary measurement equipment take into account that radioactive substances are discharged with water in a controlled way both during specified normal operation and during design basis accidents. In the case of a failure of vessels, of components and their connecting pipe lines, the released water will either be retained in the tub-built rooms or will be led by the drainage system to be collected in sumps, collecting troughs or vessels; thus, even in case of a design basis accident the radioactive substances will be discharged along designated paths that are monitored by the monitoring equipment of specified normal operation.

(11) The measurements specified under paras. 2, 3, 8 and 9 may also be carried out as nuclide-specific measurements. In this context, at least the radionuclides listed in **Table 5-1** shall be taken into account. The detection limit of the measurement equipment for determining the activity concentration shall not exceed a value of  $1 \times 10^3 \text{ Bq/m}^3$  for cobalt-60 when performing the measurement on a sample of demineralized water.

(12) The decisions required as specified under paras. 8, 9 and 10 shall take the maximum permissible nuclide-specific activity concentrations in accordance with Appendix 11 Table 6 column 3 StrISchV into account and the Equation (5-1) of Section 5.1.4 para. 2 shall be applied with a threshold value of  $c_s = 1 \times 10^4 \text{ Bq/m}^3$ .

<b>Section</b>	<b>Measurement Task</b>	<b>Measurement Procedure</b>	<b>Minimum Measurement Range Bq/m<sup>3</sup></b>	<b>Detection Limit Bq/m<sup>3</sup></b>	<b>Threshold Value Bq/m<sup>3</sup></b>	<b>Reference Nuclide</b>
5.1.3	Decision measurement	total- $\gamma$ -measurement	$1 \times 10^4$ to $1 \times 10^7$	1)	$5 \times 10^6$	Cs-137
		nuclide-specific $\gamma$ -measurement		$1 \times 10^3$ 2)	$5 \times 10^6$	Cs-137
		total- $\beta$ -measurement	$1 \times 10^3$ to $1 \times 10^6$	1)	3)	Sr-90/Y-90
		total- $\alpha$ -measurement	$1 \times 10^3$ to $1 \times 10^6$	1)	3)	Am-241
5.1.4	Continuous monitoring of discharge	total- $\gamma$ -measurement	$1 \times 10^5$ to $1 \times 10^7$	1)	$5 \times 10^6$	Cs-137
5.1.5	Detailed assessment	total- $\gamma$ -measurement		$1 \times 10^3$		Co-60
		$\beta$ -measurement of Sr-89 and Sr-90		$5 \times 10^2$		Sr-90/Y-90
		total- $\alpha$ -measurement		$2 \times 10^2$		Am-241
		nuclide-specific $\alpha$ -measurement		50		Am-241
		$\beta$ -measurement of Tritium		$4 \times 10^4$		H-3
<p>1) The detection limits (definition: cf. Section 2 para. 16) of measurement equipment for the continuous and non-continuous measurements shall not exceed the lower limit values of the minimum measurement ranges specified in <b>Tables 5-3</b> and <b>5-4</b></p> <p>2) Detection limit for Co-60</p> <p>3) The threshold value is based on the licensed value for activity discharges or is specified by the proper authority.</p>						

**Table 5-3:** Monitoring the activity concentration of the radioactively contaminated waste water (waste water discharge tank)

<b>Section</b>	<b>Measurement Task</b>	<b>Measurement Procedure</b>	<b>Minimum Measurement Range Bq/m<sup>3</sup></b>	<b>Detection Limit Bq/m<sup>3</sup></b>	<b>Threshold Value Bq/m<sup>3</sup></b>	<b>Reference Nuclide</b>
5.2	Continuous monitoring	total- $\gamma$ -measurement	$4 \times 10^4$ to $1 \times 10^7$	1)	$4 \times 10^5$	Cs-137
5.2	Measurement of coolant samples	total- $\gamma$ -measurement	$4 \times 10^3$ to $1 \times 10^7$	1)	$1 \times 10^4$	Cs-137
		nuclide-specific $\gamma$ -measurement		$1 \times 10^3$ 2)	$1 \times 10^4$	Cs-137
<p>1) cf. <b>Table 5-3</b></p> <p>2) Detection limit for Co-60</p>						

**Table 5-4:** Monitoring the activity concentration of the coolant

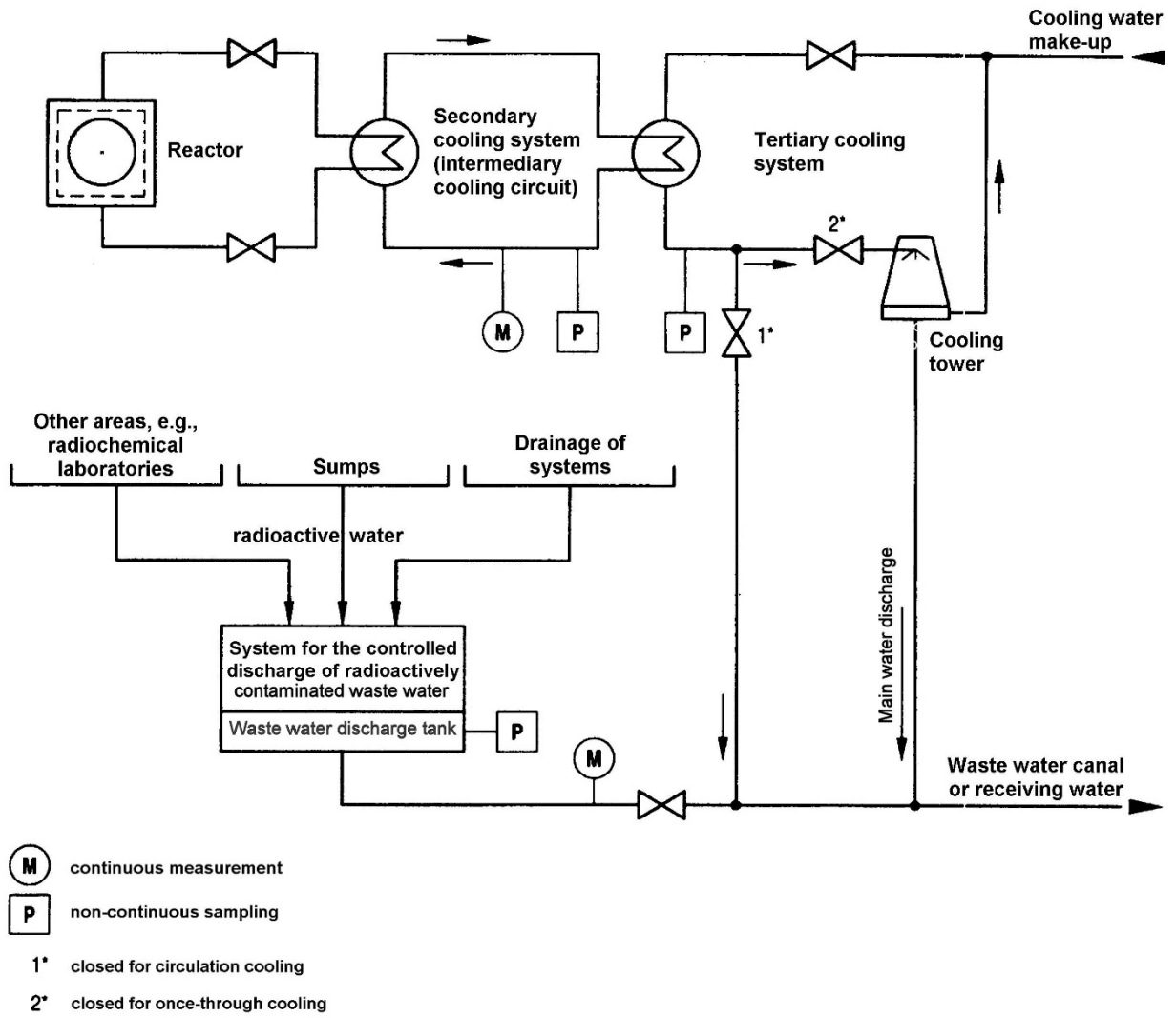

**Figure 5-1:** Monitoring of radioactive substances discharged with water; the example shown is a closed loop secondary cooling system

## 6 Design and Construction of Monitoring Equipment

### 6.1 General Requirements for Stationary Monitoring Equipment

#### 6.1.1 Design and accommodation

(1) All monitoring equipment shall be designed for the ambient conditions, measurement medium conditions and operating voltages as listed in **Table 6-1**.

(2) The measurement value may vary by no more than  $\pm 30\%$  with respect to the measurement value obtained during calibration as specified under Section 7.2.3.3 when any one of the influence parameters varies within its nominal operating ranges listed in **Table 6-1** and the other influence parameters, as far as possible, remain constant near their reference values of calibration. In this context, when monitoring gaseous radionuclides and radionuclides bound to aerosol particles, the pressure difference between the sampling point and the measuring volume shall normally not exceed 200 hPa.

(3) The reference values for the influence parameters shall be applied as listed in **Table 6-1**. With respect to filter loading, the reference value is the uncontaminated condition of the filter. With respect to back ground radiation, the reference value shall be specified by the manufacturer of the monitoring equipment.

(4) The detection limits shall be determined for an ambient dose rate of 0.25  $\mu\text{Gy/h}$  (cesium-137).

**Note:**

Details for determining the detection limits for nuclear radiation measurements are specified in DIN EN ISO 11929-1.

(5) In the first hour after a possible failure of the ventilation in the instrument rooms, the calibration value shall stay within

$\pm 30\%$  taking the expected ambient conditions into account.

(6) With regard to the resistance of measurement equipment to electromagnetic disturbances, e.g., electrostatic discharges, electromagnetic fields, interference voltages, the act EMVG shall be observed.

(7) The design of any stationary measurement equipment installed onsite or of parts of this measurement equipment for monitoring the discharge of watery substances shall be designed to comply with Protection Code IP 54 in accordance with DIN EN 60529 (protection against foreign particles and water).

(8) The measuring and sampling equipment shall be installed and accommodated in such a way

- a) that the nominal range of usage specified in the respective equipment specification is observed, and
- b) that inspection, servicing and repair can be easily carried out.

(9) The electronic components for the measurement equipment of the continuously operated monitoring equipment should be installed or accommodated in centrally located instrument rooms.

(10) It shall be possible to disassemble and decontaminate the measurement and sampling chambers. It shall be possible to flush the measuring and sampling chambers used for monitoring watery substances without having to disassemble them.

(11) With regard to monitoring the discharge of watery substances it shall be ensured that the lower energy threshold is adjusted such that all radionuclides with a gamma energy above 0.1 MeV will be registered.

<i>Influence Parameters</i>	<i>Nominal Operating Range</i>	<i>Reference Value</i>
Operating voltage - a/c supply voltage	85 % to 110 % of the nominal operating voltage	Manufacturer specification
- d/c supply voltage	specified voltage range of the d/c voltage supply	
Ambient temperature	15 °C to 40 °C	20 °C
Pressure of the ambient air	900 hPa to 1100 hPa	Manufacturer specification
Relative humidity of ambient air	10 % to 95 %, non-dewing	60 %
Temperature of the sampling medium	10 °C to 40 °C	20 °C
Pressure of the sampling medium <sup>1) 2)</sup>	700 hPa to 1100 hPa	Manufacturer specification
Relative humidity of the sampling medium <sup>2)</sup>	10 % to 95 %, non-dewing	60 %
<sup>1)</sup> The pressure difference between the sampling point and in the measurement volume shall not exceed 200 hPa		
<sup>2)</sup> Monitoring equipment for determining the discharge of gaseous radionuclides and radionuclides bound to aerosol particles		

**Table 6-1:** Nominal operating ranges and reference values for the various influence parameters

### 6.1.2 Fail-safe operation

(1) If a measurement point requires a special operating medium, e.g., a counter gas, supply of the operating medium shall be ensured and shall be monitored for possible failure.

(2) All electric loads shall be connected to the emergency power system. Redundant electric loads shall be connected to redundant power busses.

(3) All monitoring equipment that must operate continuously shall be designed to be self-monitoring. It shall be ensured that a switch-over to emergency power supply is carried out such that measuring and processing of the measurement value is not interrupted in a way that the stored data, e.g. measurement values required for an integration, would be lost.

(4) All radiation and activity monitoring systems including their peripheral equipment that are not connected to a non-interruptible power supply shall restart automatically after a power supply interruption.

(5) Wherever measurement equipment is accommodated at or inside the bypass, the flow through of the bypass shall be monitored. The flow of the measuring media shall be monitored wherever the measurement equipment is installed as a direct part of a system.

(6) A possible loss of the count rate of measurement equipment (e.g., on account of delay times) within the measurement range shall be known as a function of the count rate and shall be taken into account. Any decrease of the displayed signal with increasing amplitude of the measurement parameter (overload) is not permissible.

### 6.1.3 Factors for the statistical certainty

(1) The factor,  $k_{1-\alpha}$ , for the statistical certainty in accordance with DIN EN ISO 11929-1 has the value  $k_{1-\alpha} = 1.645$ .

(2) The factor,  $k_{1-\beta}$ , for the statistical certainty in accordance with DIN EN ISO 11929-1 has the value  $k_{1-\beta} = 1.645$ .

(3) The value of the factor  $k_{1-\gamma}$  in accordance with DIN EN ISO 11929-1 shall be set equal to 1.645.

### 6.1.4 Threshold values

(1) If the equipment requires adjustments during operation, corresponding built-in adjusting devices shall be provided. All adjusting devices on electronic instruments of the monitoring equipment shall be arranged or secured in such a way that it is largely impossible for unauthorized personnel to readjust the settings. A self-readjustment by the equipment shall be made impossible.

(2) Equipment failure and the exceedance of threshold values shall be optically displayed and acoustically annunciated and recorded in the control room or, at times when the control room is not manned, e.g., during reactor shut down, they shall be displayed at another location that is continuously manned at these times. Group alarms are permissible; however, the measurement point at the root of the alarm should be displayed in the control room, in the control room annex or at another location continuously manned. The acoustic alarms may be cancelled individually or collectively before the cause of the respective alarm has been remedied.

(3) The optical alarms in the control room indicating equipment failure or the exceedance of an upper threshold value shall also indicate the respective alarm condition.

### 6.1.5 Measurement value display and recording

(1) The measurement equipment shall normally have only one single display range. If multiple display ranges are necessary, these shall overlap each other such that

a) in the case of multiple linear display ranges, the overlap is at least 10 % of the respective measuring ranges, with the end points of the scales differing by no more than a factor of 10, and

b) in the case of multiple logarithmic display ranges, the overlap is at least one decade.

(2) If multiple measurement equipment is used to cover the entire measurement range, the individual measurement ranges shall successively overlap by at least one decade.

(3) The measurement values of stationary measurement equipment required by the present safety standard shall normally be displayed at the measurement equipment itself. The measurement values listed in **Table 6-2** shall also be displayed and recorded in the control room.

1	Vent air	Volumetric flow
2	Radioactive noble gasses	Total $\beta$ -activity concentration
3	radioactive substances bound to aerosols particles	Filter contamination (activity) Activity concentration
4	Radioactive gaseous iodine	Filter contamination (activity) Activity concentration
5	Tritium	Activity concentration
6	Coolant	Cesium-137 equivalent <sup>1)</sup>
<sup>1)</sup> May also be displayed and recorded at another location.		

**Table 6-2:** Measurement values of stationary measurement equipment to be displayed and recorded in the control room

(4) The records shall be directly visible for at least three hours and shall be well legible.

### 6.1.6 Testability

The monitoring equipment shall be designed and manufactured such that proper functioning of the individual devices can be verified within the framework of the initial tests specified under Section 7.2.1 and of the inservice inspections specified under Section 7.2.2.

## 6.2 Special Requirements for Stationary Measurement Equipment for Monitoring the Discharge of Radioactive Substances during Design Basis Accidents

### 6.2.1 Resistance to design basis accident conditions

(1) All components of the measurement equipment, e.g., sampling equipment, measurement value sensors and transducers, shall be designed such that – even during design basis accidents and their sequential effects where the functional capability of this measurement equipment is required – these components are failure resistant and can be properly operated as required by the present safety standard under the ambient conditions and measurement medium conditions expected at their respective location of installation.

(2) The ambient conditions and conditions of the measurement medium to be assumed at the respective location of installation shall be those determined in the design basis accident analyses.

(3) The measurement uncertainty and the temporal behavior of the measurement equipment shall stay within the specified tolerance limits even under conditions of design basis accidents. These tolerance limits shall be specified within the framework of system design. Tolerance limits may permissibly be dependent on the sequential course of the design basis accident.

### 6.2.2 Power supply

The measuring sensors, transducers and data storage devices shall normally be connected to a non-interruptible emergency power supply. Other components of the monitoring equipment, e.g., trace heaters of the sampling system, pumps for transferring the measurement medium, shall also be connected to the emergency power system; however, a momentary loss of power is permissible, e.g. during run-up of the emergency diesel generator.

## 7 Maintenance of Stationary Monitoring Equipment

### 7.1 Servicing and Repair

#### 7.1.1 Performing servicing and repair

Servicing and repair of the monitoring equipment shall be performed in accordance with the respective operating and repair instructions and by competent personnel.

#### 7.1.2 Recordkeeping

All performed tasks regarding servicing and repair shall be documented. The individual records shall contain at least the following information:

- a) unambiguous identification of the monitoring equipment,
- b) type of servicing or repair task performed,
- c) type and number of exchanged parts,
- d) reasons for the exchanging of parts,
- e) in case of newly installed parts: date and detailed description of the test certificates and of the verifications required under the present safety standard,
- f) details regarding outage durations,
- g) date of the servicing or repair task, as well as
- h) name and signature of the competent personnel having performed the tasks.

### 7.2 Tests

#### 7.2.1 Initial tests

##### 7.2.1.1 General requirements

The monitoring equipment or its components shall be subjected to the following tests:

- a) qualification test,
- b) calibration and calibration check,
- c) factory test, and
- d) commissioning test.

##### 7.2.1.2 Verification of suitability

(1) Prior to the initial deployment in a research reactor, it shall be verified that the monitoring equipment meets the specified requirements and will fulfill its tasks.

**Note:**

Requirements regarding the suitability verification of stationary equipment for radiation monitoring are specified in safety standard KTA 1505.

(2) The verification of suitability shall comprise the (plant-independent) verification of the equipment characteristics and the plant-specific suitability check.

(3) The plant-specific suitability check shall be performed by the proper authority or by an authorized expert appointed by the proper authority.

#### 7.2.1.3 Calibration and calibration check

(1) The monitoring equipment including the volume measurement equipment shall be calibrated prior to deployment. This calibration may also be carried out on a similar-type device.

(2) The measurement equipment for monitoring noble gases shall be calibrated with argon-41. The discrimination value of the equipment shall be known for the radionuclides xenon-133 and krypton-85. The measurement equipment for continuous gamma spectrometric measurements specified under Section 3.2.2 shall be calibrated with xenon-133 and krypton-85.

(3) The measurement equipment for monitoring radionuclides bound to aerosol particles shall be calibrated for beta emitters with technetium-99 or cobalt-60 as well as with chlorine-36 or cesium-137, and for gamma-radiation with barium-133 and cesium-137. The energy dependency of the discrimination value shall be known for beta radiation in the energy range from 150 keV to 2500 keV and for gamma radiation in the energy range from 100 keV to 1700 keV. In order to reduce the probability of detecting interfering nuclides or background radiation, it is permissible to upward adjust the lower gamma radiation threshold of the measurement equipment for monitoring radionuclides bound to aerosol particles to a maximum value of 250 keV.

(4) The measurement equipment for iodine monitoring shall be calibrated with iodine-131.

(5) The measurement equipment for tritium monitoring as specified under Section 3.5.2 shall be calibrated with water containing tritium.

(6) The measurement equipment for monitoring water shall be calibrated with cesium-137. The discrimination shall be known for gamma radiation in the energy range from 100 keV to 1700 keV.

(7) During initial calibration a set of calibration sources shall be specified for use in checking one display value in one of the lower and one display value in one of the upper decades of the measuring range. For this purpose, the following solid calibration sources shall be available:

- a) With regard to monitoring noble gases: Cobalt-60 or technetium-99 for the beta emitter measurement points, barium-133 or cobalt-57 for the gamma radiation measuring points, as well as americium-241 and europium-152 for the continuous gamma spectrometric measurement equipment,
- b) With regard to monitoring radionuclides bound to aerosol particles: Cobalt-60 or technetium-99 for the beta emitter measuring points, and barium-133 or cobalt-57 for the gamma radiation measurement points,
- c) With regard to monitoring iodine: Barium-133,
- d) With regard to monitoring water: Cesium-137 and one solid calibration source to check the lower energy threshold,
- e) With regard to monitoring tritium as specified under Section 3.5.2: Cesium-137.

(8) Following the initial calibration of the monitoring equipment, a re-calibration value shall be determined with a solid calibration source in a defined and reproducible geometry that can later be used to check the calibration and to connect additional similar-type devices.

#### 7.2.1.4 Factory test

(1) A factory test shall be carried out to verify proper manufacture and the perfect functioning of the monitoring equipment.

(2) If the monitoring equipment is comprised of components produced by various manufacturers, the factory tests to verify proper manufacture and perfect functioning of these components shall be carried out at the respective manufacturing plants.

(3) The factory test shall be performed as a production test and shall include:

- a) visual examination,
- b) determination of the initial value as a function of the specified fluctuation of the operating voltage,
- c) determination of the characteristic by a pulse or power generator with at least one test value per decade of the measurement range,
- d) determination of the overload resistance (by electronic means or by means of a calibration source), and
- e) function test with a calibration source.

(4) The factory test shall be performed by factory experts, however, in substantiated cases, in the presence of the proper authority or of an authorized expert appointed by the proper authority.

#### 7.2.1.5 Commissioning Test

(1) The post-installation commissioning test shall verify the correct manufacture and functioning of the monitoring equipment. The commissioning test shall consider:

- a) manufacture of the monitoring equipment,
- b) installation of the monitoring equipment,
- c) display (with at least one test value per decade of the measurement range),
- d) calibration check (by means of a solid calibration source),
- e) threshold value setting and signaling system,
- f) connection to the emergency power supply,
- g) automatic restart after interruption of the power supply,
- h) flow monitoring,
- i) measured value processing,
- k) equipment failure alarm,
- l) supply of operating media, and
- m) monitoring volumetric flow of vent air.

(2) The commissioning test shall be carried out by the operating utility and, to the extent specified by the proper authority, by or in the presence of the proper authority or of an expert appointed by the proper authority.

### 7.2.2 Inservice inspections

#### 7.2.2.1 General requirements

(1) In the course of operation, the monitoring equipment shall be subjected to inservice inspections.

#### Note :

These inspections include regularly recurring tests and tests after repairs.

(2) The inservice inspections shall be possible without manual changes of the circuitry (e.g., soldering).

(3) The tests shall be carried out in accordance with test documents in which the test methods for each individual test are specified. These documents shall include the following data:

- a) test specification or test instruction,
- b) test object and test location,
- c) testing equipment to be used,
- d) test conditions, and
- e) required values.

#### 7.2.2.2 Regularly recurring tests

(1) Regularly recurring tests shall be carried out to verify the proper functioning of the monitoring equipment. The required tests and test frequencies are listed in **Table 7-1**.

(2) The verification of the calibration specified in row No. 1 of **Table 7-1** shall be carried out in the same geometry and with a solid calibration source as are specified for the initial calibration under Section 7.2.1.3 para. 7. The required value of the display shall be achieved within the tolerance specified in the testing manual.

(3) These tests shall be carried out by the operating utility or by the proper authority or by an expert appointed by the proper authority.

(4) The type of inservice inspection, their extent and testing intervals as well as the respective participation of the proper authority or of the authorized expert appointed by proper authority shall be specified in a testing schedule.

#### 7.2.2.3 Tests after a repair

After completion of a repair task, proper functioning of the corresponding equipment shall be verified by a carrying out a commissioning test as specified under Section 7.2.1.5 to an extent corresponding to the extent of the repair task.

### 7.3 Removal of Defects

The repair times for the removal of any defects and the possible substitution measures shall be specified in the operating manual. The defects shall be documented together with the measures taken to remove these defects.

### 7.4 Test certificates

All tests performed shall be documented by test certificates. The test certificates shall be stored for a period of 10 years. They shall contain at least the following information:

- a) date of the test,
- b) test object,
- c) type of test,
- d) test documents,
- e) test results,
- f) in case of defects: specified deadline for removal of the defects or for the exchange of the test object, and
- g) name and signature of the tester.

1	2	3	4	5
No.	Test Object	Testing Procedures	Test Frequency <sup>1)</sup>	
			by operator	by proper authority or an expert appointed by proper authority
1	Monitoring equipment	a) visual inspection	during plant walk-through	annually
		b) checking the calibration with solid calibration source	quarterly	annually
		c) in the case of counter tubes: checking of the plateau	–	annually
2	Test and servicing records	Visual inspection	–	annually
3	Electronic modules	<p>Feed-in of suitable signals at designated input locations, or simulation of signals directly at the transducer input with at least one value per decade of the measurement range <sup>2)</sup> for the integral test of the transducer.</p> <p>To test the transducer output as well as the registering equipment such as displays, recorders or surveillance computers, at least one value per decade of the measurement range shall be simulated; in the case of computer-based measurement equipment, it is permissible to create this value via the keyboard.</p> <p>Comparison of all displays with the corresponding recordings</p>	annually	annually
4	Signaling system	a) Operational availability: visual inspection	during plant walk-through	annually
		b) Failure signals: by interrupting power supply or by interrupting the connection between detector and transducer or by specifying a value below the failure threshold	quarterly	annually
		c) Hazard alarms: using radiation source, or electrically	quarterly	annually
		d) Flow monitoring: by varying the volumetric flow to values above the alarm thresholds	annually	annually
5	Flow monitoring and operating medium supply			
	without automatic function check	Visual inspection	during plant walk-through	annually
	with automatic function check	Comparison of the required value with the actual value	quarterly	annually
6	Vent air volumetric flow	Comparison of the required value with the actual value at nominal volumetric flow	annually	annually
7	Sampling system	Visual inspection, check of the automatic switching of ventilators or blowers	annually	annually
<sup>1)</sup> When a test under column 5 is carried out, the test under column 4 may be dispensed with at this point in time. <sup>2)</sup> The testing method for simulating detector signals at the input of the transducer for the integral test of transducers and measurement circuits signals with at least one value per decade is not required in the case of digital measurement equipment, provided, the software code has been properly qualified. In this case it is sufficient to feed-in one signal in the uppermost decade, provided, the processing electronics does not perform any switch-overs in the entire measurement range. Even this latter test may be dispensed with, provided, one of the signals from the calibration check falls into the upper decade of the measuring range.				

**Table 7-1:** Regularly recurring tests (inservice inspections)



## 8 Measurement Results

### 8.1 Documentation

#### 8.1.1 Flow diagram

(1) The sampling and monitoring equipment provided for monitoring the discharge of gaseous radioactive substances, radioactive substances bound to aerosol particles and liquid radioactive substances shall be depicted in clearly structured flow charts. The different types of sampling and measurements shall be characterized by correspondingly different symbols.

(2) The respective description for each of the various flow charts, e.g., in tabular form, shall list the required measurement objective and measurement procedure for each sampling and monitoring equipment. With respect to the samplings, the objective, type, location and frequency as well as the required measurements shall be specified. With respect to the monitoring equipment, the measurement objectives and the respective measurement-technical requirements, in particular, measurement procedure, measurement equipment including shielding, calibration, measurement ranges, detection limits and measurement uncertainties, shall be specified. Likewise with respect to the measurement laboratory, the measurement tasks and the measurement-technical requirements shall be specified.

#### 8.1.2 Extent of documentation

The documentation shall be planned such that a complete verification of the discharge of radioactive substances is possible. This includes records on:

- a) Activity measurements  
(individual nuclide concentrations and discharge rates),
- b) Samplings  
(continuous, non-continuous, point in time, duration),
- c) Volumetric flow of stack vent air,
- d) Water amounts  
(types of water, point in time, duration, discharge location),  
and
- e) persons responsible and the performing personnel.

#### 8.1.3 Evidential samples

The type, quantity and retention period for the evidential samples shall be agreed upon with the proper authority.

### 8.2 Report to the Proper Authorities

#### 8.2.1 Contents of report

Reports to the proper authority regarding the discharge of gaseous radioactive substances, radioactive substances bound to aerosol particles or liquid radioactive substances shall include the corresponding data on the

- a) quantity of vent air,
- b) quantity of waste water,
- c) licensed limit values,
- d) nuclide-specific discharge of activity and the respective measurement uncertainties,  
and
- e) Responsible and performing persons.

and on the lowest and highest decision thresholds achieved with the various measurement equipment in the reporting period.

#### 8.2.2 Detailed assessment

The nuclide-specific verification of the discharged activity and the comparison with the licensed limit values shall be carried out at least once in every calendar year. Radionuclides with activity concentrations below the achieved decision thresholds do not need to be taken into consideration (NC) in this detailed assessment.

#### 8.2.3 Report forms

(1) The regular reporting shall normally be carried out with the report forms of **Figures 8-1** and **8-2**.

(2) Only such values shall be listed in the column "Discharged Activity" that result from measurements of the activity concentrations exceeding the respective decision threshold. If no values in exceedance of the decision threshold (DT) were determined, the corresponding fields shall be marked as "smaller DT" or "NC" (not taken into consideration).

(3) In the column „Discharged Activity and its uncertainty“ the summation of measurement uncertainties according to Gaussian error propagation shall be applied and list in the in the appropriate line.

Discharge of Gaseous Radionuclides and Radionuclides Bound to Aerosol Particles (KTA 1507)					
Reactor:		Year:		Vent Air Volume in m <sup>3</sup> :	
				Overall Loss Factor:	
Radionuclide	Decision Threshold and Detection Limit <sup>1)</sup> of Activity Concentration in Bq/m <sup>3</sup>		Discharged Activity <sup>2)</sup> in Bq and its uncertainty (Bq)	Licensed Value of Activity Discharge in Bq/a	Remarks
	DT max.	DL max.			
<b>Noble gasses:</b>					
Ar-41					
Kr-85					
Kr-85m					
Kr-87					
Kr-88					
Xe-131m					
Xe-133					
Xe-133m					
Xe-135					
Xe-135m					
Xe-138					
Other radioactive noble gasses					
<b>Sum</b> of radioactive noble gasses <sup>3)</sup>					
<b>Sum</b> of radioactive noble gasses Total β-activity <sup>4)</sup>					
H-3 in steam phase					
C-14 as CO <sub>2</sub>					
<b>Sum</b> of gaseous radionuclides or gaseous compounds (except for iodine)					
<b>Iodine:</b>					
I-131 gaseous					
I-131 bound to aerosol particles					
<b>Sum</b> of iodine-131					
Other iodine nuclides					
<b>Radionuclides bound to aerosol particles <sup>5)</sup>:</b>					
Cr-51					
Mn-54					
Co-58					
Fe-59					
Co-60					
Zn-65					
Zr-95					
Nb-95					
Ru-103					
Ru-106					
Ag-110m					
Sb-124					
Sb-125					
Cs-134					
Cs-137					
Ba-140					
La-140					
Ce-141					
Ce-144					
Other γ-radiating radionuclides					
Sr-89					
Sr-90					
U-234					
Pu-238 + Am-241					
Pu-239 + Pu 240					
Cm-242					
Cm-244					
Other α-emitting radionuclides					
<b>Sum</b> of radionuclides bound to aerosol particles					

<sup>1)</sup> DT max. and LT max. are the maximum decision thresholds and detection limits achieved with a single measurement in the detailed assessment period.

<sup>2)</sup> unk. = unknown

<sup>3)</sup> In case of a continuous nuclide-specific measurement for the detailed assessment.

<sup>4)</sup> In case of a non-continuous nuclide-specific measurement for the detailed assessment.

<sup>5)</sup> Includes correction by overall loss factor (even in the case of strontium isotopes and the α-emitting radionuclides).

**Figure 8-1:** Example of a report form for reporting the activity discharged with vent air

Discharge of Radioactive Substances with Water (KTA 1507)			Sheet	of	
Reactor:		Year:			
Water discharge: m <sup>3</sup>		Type of water:			
Radionuclide	Decision Threshold and Detection Limit <sup>1)</sup> in Bq/m <sup>3</sup>		Discharged Activity <sup>2)</sup> in Bq and its uncertainty (Bq)	Licensed Value in Bq/a	Remarks
	DT. max,	DL max.			
Cr-51					
Mn-54					
Co-58					
Fe-59					
Co-60					
Zn-65					
Zr-95					
Nb-95					
Ru-103					
Ru-106					
Ag-110m					
Sb-124					
Sb-125					
I-131					
Cs-134					
Cs-137					
Ba-140					
La-140					
Ce-141					
Ce-144					
Other $\gamma$ -radiating radionuclides					
Sr-89					
Sr-90					
Fe-55					
Ni-63					
<b>Sum</b> of $\gamma$ - and $\beta$ -emitters					
Overall $\alpha$ -activity					
U-234					
Pu-238					
Pu-239 + Pu 240					
Am-241					
Cm-242					
Cm-244					
Other $\alpha$ -emitting radionuclides					
Sum of $\alpha$ -emitters					
<b>Overall sum</b> without Tritium					
Tritium					

<sup>1)</sup> DT max. and LT max. are the maximum decision thresholds and detection limits achieved with a single measurement in the detailed assessment period.

<sup>2)</sup> unk. = unknown

**Figure 8-2:** Example of a report form for the activity discharged with water

## Appendix A

### Instruction for Preparing Monthly, Quarterly and Annual Mixture Samples for the Detailed Assessment Measurements

#### A 1 General Requirements

Monthly, quarterly and annual mixture samples shall be prepared in proportion to the amount of waste water discharged from the waste water discharge tank in preparation of the detailed assessments measurements. First, the monthly mixture samples shall be prepared, then, from these the quarterly mixture samples and from the latter the annual mixture samples.

#### A 2 Acidification and Support Stabilization

The samples taken from the waste water discharge tank for preparing the monthly mixture samples shall be acidified and, subsequently, stabilized by mixing in the Carrier Solutions 1 and 2 (cf. **Table A-1**).

#### A 2.1 Acidification of the Samples

The samples taken from the waste water discharge tank shall be acidified by adding 10 ml concentrated nitric acid to every one liter of the sample. After adding the nitric acid the acidity (pH-value) should lie between 1 and 2. The pH-value shall be checked.

#### A 2.2 Stabilization of the Samples

Carrier Solution 1 shall be prepared by dissolving the 13 substances specified in **Table A-1** in 100 ml of hydrochloric acid (0.1 mol/l). Carrier Solution 2 shall be prepared by dissolving the two substances specified in **Table A-1** in 100 ml of water. The samples shall be stabilized by mixing 1 ml from each of the carrier solutions into every one liter of the sample.

<i>Carrier Solution 1</i>		<i>Carrier Solution 2</i>	
<i>Compound</i>	<i>Amount in g</i>	<i>Compound</i>	<i>Amount in g</i>
1. CrCl <sub>3</sub> ·6 H <sub>2</sub> O	2.0	1. SbCl <sub>3</sub> ·6 H <sub>2</sub> O	1.1
2. MnCl <sub>2</sub> ·4 H <sub>2</sub> O	1.4	2. Tartaric acid	4.0
3. FeCl <sub>3</sub> ·6 H <sub>2</sub> O	1.9		
4. CoCl <sub>2</sub> ·6 H <sub>2</sub> O	1.6		
5. ZrOCl <sub>2</sub> ·8 H <sub>2</sub> O	1.4		-
6. CsCl	0.5		
7. BaCl <sub>2</sub> ·2 H <sub>2</sub> O	0.7		
8. LaCl <sub>3</sub> ·7 H <sub>2</sub> O	1.0		
9. CeCl <sub>3</sub> ·7 H <sub>2</sub> O	1.0		
10. SrCl <sub>2</sub> ·6 H <sub>2</sub> O	1.2		
11. YCl <sub>3</sub> ·6 H <sub>2</sub> O	1.3		
12. ZnCl <sub>2</sub>	0.8		
13. NiCl <sub>2</sub> ·6 H <sub>2</sub> O	1.6		

**Table A-1:** Chemical compounds for the production of Carrier Solutions 1 and 2

## Appendix B

### Regulations Referred to in this Safety Standard

(Regulations referred to in this safety standard are valid only in the versions cited below. Regulations which are referred to within these regulations are valid only in the version that was valid when the latter regulations were established or issued.)

AtG		Act on the Peaceful Utilization of Atomic Energy and the Protection against its Haz-ards (Atomic Energy Act) Atomic Energy Act in the version promulgated on July 15, 1985 (BGBl. I, p. 1565), most recently changed by article 1 of the act dated December 4, 2022 (BGBl. I, p. 2153)
StrlSchG		Act on the Protection against the Harmful Effect of Ionising Radiation (Radiation Protection Act - StrlSchG) Radiation Protection Act of June 27, 2017 (BGBl. I, p. 1966), most recently changed by the promulgation of January 3, 2022 (BGBl. I, p. 15)
EMVG		Act on the electromagnetic compatibility of operating components (EMVG) of September 26, 1998 (BGBl. I, No. 64, p. 2882), most recently changed by Article 51 of the act of June 23, 2021 (BGBl. I p. 1858)
WHG		Act on the regulation of the water household (Water resources act – WHG) of July 31, 2009 (BGBl. I p. 2585) most recently changed by Article 1 of the Act of January 4, 2023 (BGBl. I, p. 2771)
StrlSchV		Ordinance on the Protection against the Harmful Effects of Ionising Radiation (Radiation Protection Ordinance - StrlSchV) Radiation Protection Ordinance of November 29, 2018 (BGBl. I, p. 2034, 2036), most recently changed by article 1 of the ordinance dated October, 2021 (BGBl. I p. 4645)
KTA 1505	(2022-11)	Suitability verification of the stationary measurement equipment for radiation monitoring
DIN EN 1822-1	(2019-10)	High efficiency air filters (EPA, HEPA and ULPA) - Part 1: Classification, performance testing, marking; German version EN 1822-1:2019
DIN ISO 2889	(2012-07)	Sampling airborne radioactive materials from the stacks and ducts of nuclear facilities (ISO 2889:2010)
DIN EN ISO 11929-1	(2021-11)	Determination of the characteristic limits (decision threshold, detection limit and limits of the coverage interval) for measurements of ionizing radiation - Fundamentals and application - Part 1: Elementary applications (ISO 11929-1:2019); German version EN ISO 11929-1:2021
DIN EN 60529	(2014-09)	Degrees of protection provided by enclosures (IP Code) (IEC 60529:1989 + A1:1999 + A2:2013); German version EN 60529:1991 + A1:2000 + A2:2013
DIN EN 60529 Corrigendum 1; VDE 0470-1 Corrigendum 1:2017-02		Degrees of protection provided by enclosures (IP Code) (IEC 60529:1989 + A1:1999 + A2:2013); German version EN 60529:1991 + A1:2000 + A2:2013, Corrigendum to DIN EN 60529 (VDE 0470-1):2014-09, (IEC 60529 Edition 2.2 Corrigendum 2:2015); German version EN 60529:1991/AC:2016-12
DIN EN 60529 Corrigendum 2; VDE 0470-1 Corrigendum 2:2019-06		Degrees of protection provided by enclosures (IP Code) (IEC 60529:1989/A2:2013/COR1:2019); German version EN 60529:1991/A2:2013/AC:2019-02
KTA-GS 82	(2016-11)	Determination of the characteristic limits (decision threshold, detection limit and limits of the confidence interval) for nuclear radiation measurements according to DIN ISO 11929 - Application examples for the KTA safety standard series 1500, Revision 1